



ONE KILOWATT—ONE CHASSIS

GL-1614 and GL-807 Drive Push-Pull GL-8000 Kilowatt Final

Flash!—See P-5 on the R-9'er, fully described in last issue of Ham News

Page 1, 2, 3 and 4—GL-8000 transmitter ● Page 5—More on the R-9'er ● Page 6—Forced-Air Cooling
Page 7—Questions and Answers — Tricks and Topics ● Page 8—GL-8000 Technical Data

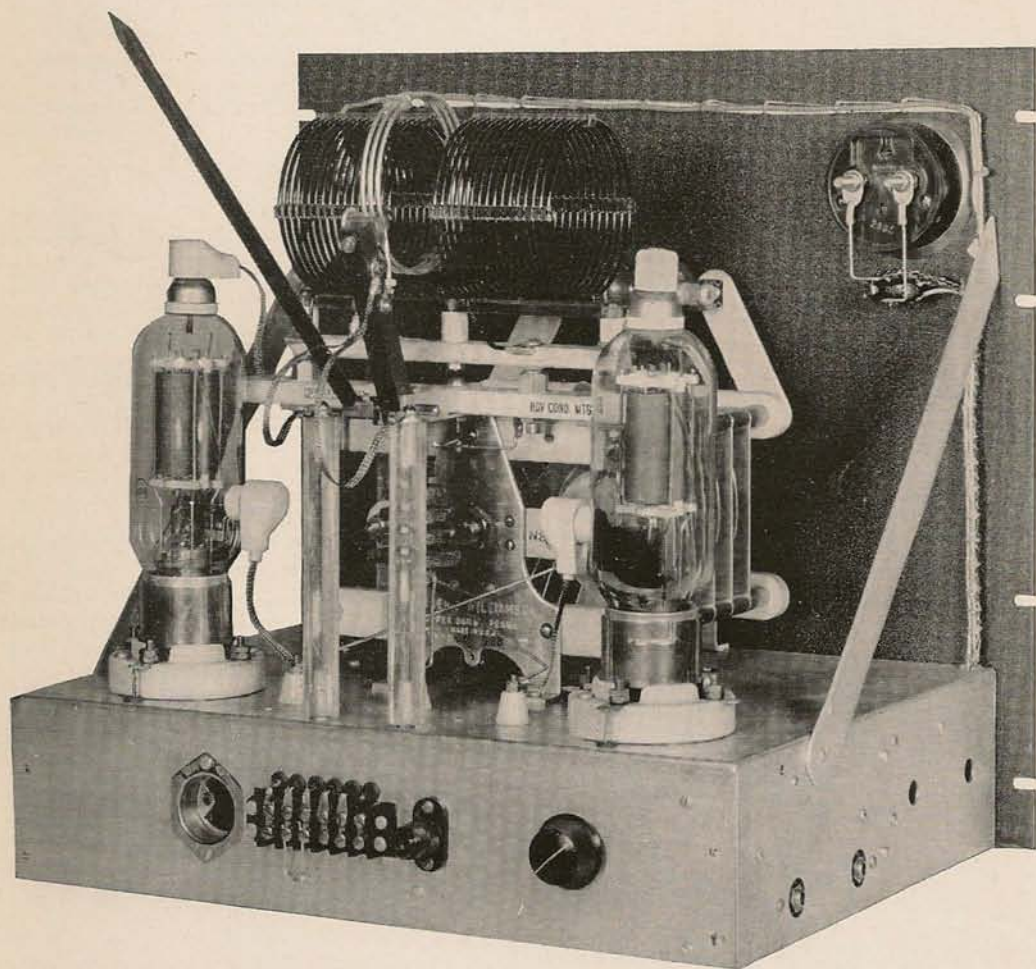

Fig. 1—Back-of-Panel View of GL-8000 Transmitter

The transmitter shown in Fig. 1 above illustrates that compact transmitter design need not apply only when trick circuits are used. This GL-8000 rig is straightforward in all respects. The General Electric GL-8000 triode is exceptionally easy to drive and the GL-807 buffer provides adequate drive for operation on 80, 40 and 20 meters. A GL-1614 used as a Pierce oscillator eliminates a tuning control and allows rapid crystal switching.

ELECTRICAL CIRCUIT

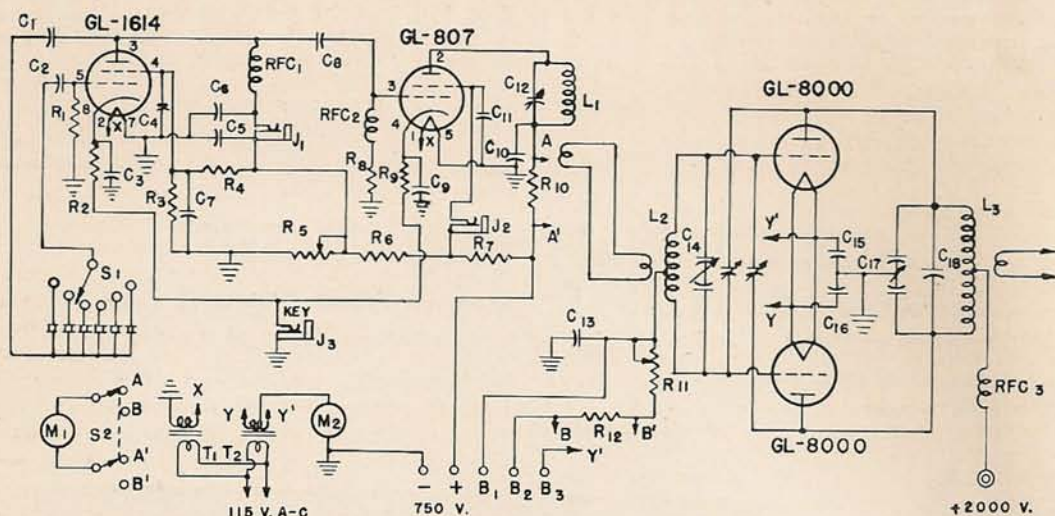

Fig. 2—Circuit Diagram of GL-8000 Transmitter

CIRCUIT CONSTANTS

C_1, C_2, C_4, C_6	$= 0.002$ mf 400 volt mica	M_2	$=$ Milliammeter, 0-500 ma (G.E. No. 93X101)
C_3, C_9	$= 0.01$ mf 400 volt mica	R_1	$= 50,000$ ohm, 1 watt
C_5, C_7	$= 8$ mf 450 volt electrolytic	R_2	$= 200$ ohm, 2 watt
C_8	$= 500$ mmf 400 volt mica	R_3	$= 75,000$ ohm, 2 watt
C_{10}	$= 0.005$ mf 2500 volt mica	R_4	$= 40,000$ ohm, 2 watt
C_{11}	$= 0.005$ mf 600 volt mica	R_5	$= 50,000$ ohm, 50 watt adjustable with slider
C_{12}	$= 50$ mmf variable (Millen No. 22950)	R_6	$= 1,500$ ohm, 25 watt
C_{13}	$= 0.005$ mf 1000 volt mica	R_7	$= 10,000$ ohm, 25 watt
C_{14}	$= 100$ mmf (per section) variable Millen No. 23100	R_8	$= 60,000$ ohm, 2 watt
C_{15}, C_{16}	$= 0.01$ mf 400 volt mica	R_9	$= 100$ ohm, 10 watt
C_{17}	$= 58$ mmf (per section) variable butterfly with attached neutralizing condensers. (B & W CX58B-N3)	R_{10}, R_{12}	$= 50$ ohm, 1 watt
C_{18}	$= 12$ mmf vacuum capacitor (G.E. GL-1L25)	R_{11}	$= 5,000$ ohm, 25 watt potentiometer
J_1, J_2, J_3	$=$ Single-circuit, normally closed jack	RFC_1, RFC_2	$= 2.5$ millihenry r-f choke, 125 ma
L_1	$=$ B & W Junior Inductor, end link	RFC_3	$= 4$ millihenry r-f choke, 750 ma
L_2	$=$ B & W Junior Inductor, center link	S_1	$=$ Six-position tap switch (Mallory No. 1316L)
L_3	$=$ B & W HD Inductor, variable link	S_2	$=$ DPDT switch
M_1	$=$ Milliammeter, 0-200 ma (G.E. No. 93X99)	T_1	$=$ Filament transformer, 6.3 V (Stancor P8544)
		T_2	$=$ Filament transformer, 10 V, 9 amp (Thordarson 19F87)

GENERAL FEATURES

Present day transmitter design often makes use of tetrodes or beam-power tubes so that driving power requirements are held to a minimum. This idea is a good one, but has one disadvantage in that tetrodes or beam-power tubes are sometimes rather tricky in operation. On the other hand it is relatively easy to get triodes to operate properly, although more driving power is required. The General Electric GL-8000 triode will handle an in-

put of 500 watts for c-w use, and yet requires only 8 watts of drive. This fact has been used to advantage in the one-chassis kilowatt. A pair of GL-8000 tubes becomes the final of a kilowatt rig, and the 16 watts of required drawing power is supplied by a GL-807. The entire transmitter is capable of being assembled and placed on the air with a minimum of fuss.

The unit is designed to operate primarily as a c-w transmitter on the main c-w bands, 80, 40 and 20 meters. Standard Barker and Williamson plug-in coils are used for convenience in changing bands. A six-position crystal switch is incorporated. All controls are brought to the front panel except the swinging link control. Two meters permit adequate operational metering of three circuits—GL-807 plate current and final grid and plate current. Initial adjustment metering is accomplished by the use of two additional jacks.

Although intended for use as a c-w transmitter, the one-chassis kilowatt may be modulated. For phone work the input should be reduced to approximately 700 watts. Under these conditions the tubes each require 8.5 watts of driving power. It is interesting to note that operation is recommended at CCS ratings in order to take advantage of low driving power. Two GL-8000 tubes will take an input of 1500 watts on c-w or 1000 watts on phone (ICAS ratings), but require approximately 40 watts of drive. When used at CCS ratings a pair of GL-8000 tubes take an input of 1000 watts on c-w and 660 watts on phone, and yet require a total of only 16 watts drive. In addition, the GL-8000 tubes should have exceptionally long life if operated at CCS ratings.

CIRCUIT DETAILS

Referring to Fig. 2, the circuit consists of three stages—crystal oscillator, buffer-doubler amplifier and final amplifier.

A Pierce type oscillator was decided upon so that a tuning control could be eliminated. By using a General Electric GL-1614 (radio-frequency version of the 6L6) as the crystal oscillator tube, adequate power is available to drive the GL-807. Voltage for the GL-1614 is obtained from a bleeder consisting of resistors R_5 , R_6 and R_7 . Plate voltage may be adjusted by the tap on R_5 . A supplementary bleeder for the screen voltage is formed by R_3 and R_4 . Keying is improved by the use of this type of voltage regulation.

Two 8 mf condensers were added in the oscillator circuit to eliminate a chirp which was present (C_5 and C_7). Keying is done in the common cathode lead from the GL-1614 and the GL-807.

The buffer-doubler stage employing the GL-807 is a standard circuit. The 60,000 ohm grid resistor, R_8 , provides a high bias so that the efficiency is good when the GL-807 acts as a doubler. Screen voltage is taken from the same bleeder as the GL-1614 plate voltage.

The grid circuit of the final provides for several types of bias. Rated grid current (50 mils) through R_{11} produces a bias of 250 volts. This is more than adequate for c-w operation, but gives no protection for the GL-8000 tubes. A 45-volt battery may be connected to B_2 and B_3 in order to partially cut off the final tubes, and the potentiometer R_{11} adjusted to give proper operating bias. If a bias pack is already available, incorporating its own bleeder resistor, it may be connected to B_2 and B_3 , with a short between B_1 and B_2 . Or, R_{11} could be rotated so that it is shorted out, and then B_1 and B_2 would not need to be shorted.

The remainder of the final is quite straightforward. The neutralizing condensers shown in the diagram are not marked as they are a part of the B & W tank condenser C_{17} . A vacuum condenser (General Electric GL-1L25) is shown as C_{18} . This is used only for operation on 80 meters.

CONSTRUCTIONAL DETAILS

A 17 inch by 13 inch by 4 inch chassis is used together with a 17 1/2 inch relay rack panel. With reference to Fig. 3, the exciter stages are mounted on partitions. One main partition is made of one-fourth inch aluminum, and is mounted in the center of the chassis. Two thinner partitions are mounted by angle brackets between the aluminum partition and the front of the chassis. These thin partitions are mounted four inches apart, so that the shaft for the final grid condenser goes between them.

The upper right section contains the GL-1614, the crystal selector switch, and the crystal socket mounting. The latter consists of six Millen No. 33102 sockets mounted on a 1/8 inch thick piece of aluminum. This plate is mounted on the chassis by four brackets. The upper middle section contains all component parts for the oscillator and buffer stages, with the exception of the GL-807 plate circuit components, which are mounted in the upper left section. The one-half inch holes in the chassis are for ventilation purposes.

Fig. 3 shows clearly the mounting of the GL-807 plate coil and the GL-8000 grid tank coil and condenser. The 25-watt resistor mounted directly below the grid tuning condenser is R_7 . The 25-watt potentiometer to the left is R_{11} , and the resistor mounted vertically in the corner is R_6 . The adjustable bleeder, R_5 , is mounted directly above R_6 .

Top-of-chassis layout is shown clearly in Fig. 4. The Barker & Williamson butterfly condenser is mounted directly on the chassis. Two auxiliary brackets are connected to the condenser frame so that the vacuum condenser may be mounted. Thirty-ampere fuse clips are used for connecting the General Electric GL-1L25 condenser to the brackets.

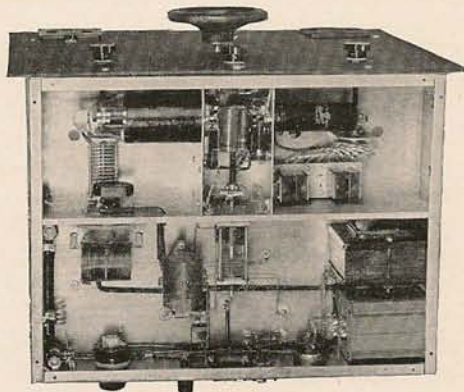

Fig. 3—Under-Chassis View of GL-8000 Transmitter

The one-half inch bakelite rod which is mounted on the left-hand panel support is a combination neutralizing tool and swinging-link control. One end is filed to a flat wedge so that it fits the slots on the neutralizing condensers. The other end is drilled out, and a 10-32 machine screw is threaded-in. The head is then cut off so that the 10-32 screw will fit into the solid coupling on the swinging-link shaft. Figs. 1 and 4 show this in detail.

Front-panel layout is shown in Fig. 5. Meter holes are drilled with centers 3 inches down from top of panel and 3 inches in from the side of the panel. The main tuning control is drilled in the center of the panel, $7\frac{1}{2}$ inches up from the bottom of the panel.

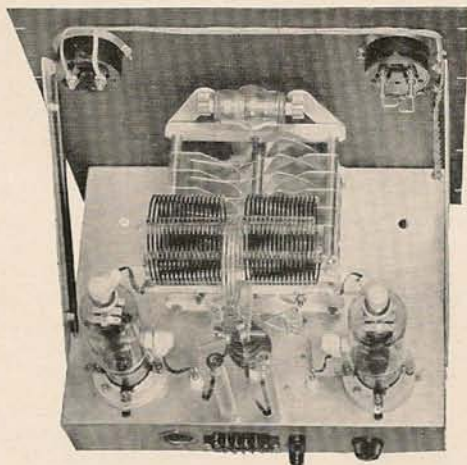

Fig. 4—Airplane View of GL-8000 Transmitter

The three small knobs, from left to right are: GL-807 plate tank tuning, GL-8000 grid tuning, and crystal switch. The jack directly below the center knob is the keying jack. These controls may be mounted in whatever position suits the internal parts arrangement.

METERING

Two meters are used. One, a 0-200 milliammeter, is used to measure the plate current to the GL-807 or the grid current to the final. Switching is accomplished by S_2 . This DPDT switch is mounted directly below the meter. A 0-500 milliammeter is used to measure final plate current (M_2). Two jacks, J_1 and J_2 , measure GL-1614 plate current and GL-807 screen current, respectively, and are useful when first adjusting the transmitter. Fig. 1 shows the location of these jacks on the side of the chassis.

OPERATING ADJUSTMENTS

The GL-1614 stage should be adjusted for proper operation first. Apply 750 volts to the terminal on the rear and adjust R_3 until the plate voltage on the GL-1614 is approximately 150 volts. It is also advisable to insert two 0.060 amp pilot light bulbs, wired in parallel, in series with the crystal switch. These lamps will protect your crystals until tuning-up is complete. The grid current in the GL-807 stage should now be about .003 amp with the GL-1614 plate current in the order of .025 amp. Under these conditions crystal current runs about .100 amp. In all the above adjustments jack J_2 should be open-circuited and the plate cap terminal should be removed from the GL-807.

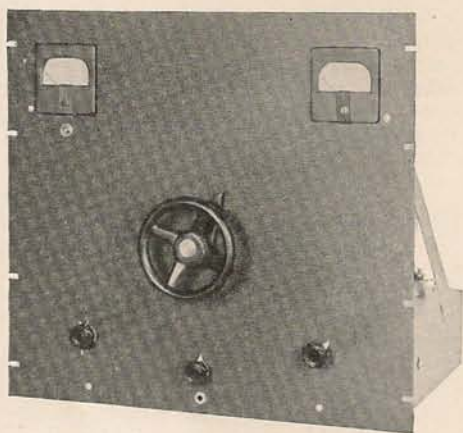

Fig. 5—Front-Panel View of GL-8000 Transmitter

The proper coil should now be placed in the GL-807 plate circuit, and screen and plate voltage applied. With no load the GL-807 plate current should dip to approximately 5 mils at resonance. The final grid coil should now be plugged in and final grid current measured. This should run from 60 to 80 mils, depending upon the frequency. When final plate voltage is applied, the grid current will drop down to rated value, of approximately 50 mils. (Terminals B_2 and B_3 must be tied together or no grid current will flow.)

Protective bias should now be tied to terminals B_2 and B_3 and the amplifier should be neutralized. The B & W neutralizing condensers which are mounted on the rear of the B & W butterfly condenser provide an extremely sure-fire method of neutralization.

The final step is to apply plate voltage. For c-w work the final should be run at 2000 volts and 0.500 amp, while for phone work the voltage should be reduced to 1600 volts and the current to 0.420 amp.

Here it is! More on the R-9'er

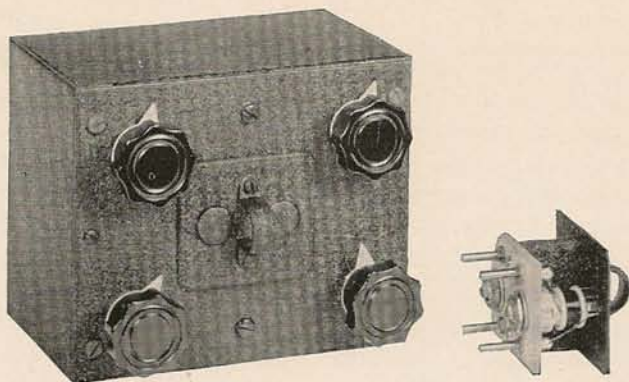

Fig. 6—Front View of R-9'er and Plug-in Coil
(Fully Described in HAM NEWS, Vol. 1—No. 4)

There has been a great deal of interest shown in the one tube preamplifier which was described in the last HAM NEWS (Nov.-Dec. 1946). Many of you have written in asking if the "R-9'er" will work on 20 meters. In order to answer this and other questions further experiments have been run.

The coils are the most important part of the preamplifier. Unless the coils are of a sufficiently high Q very little gain may be achieved. This is because the band width of the "R-9'er" is jointly dependent upon the Q of the coil, the resistance across the coil and the distributed capacitance in the circuit. It is desirable to have a coil with a sufficiently high Q that the band width is effectively dependent only upon the resistance across the coils and the distributed capacitance. (R_1 and R_5 , referring to the original diagram.)

Coils wound with a large diameter wire which is poorly insulated will have a low Q . Similarly, the Q will be lowered if it is necessary to overwind the coil, that is, if more than one layer of wire is used. High Q coils will be achieved if the wire is of a diameter which will allow the proper number of turns to fit exactly onto the coil form in one layer. It is very important also that the wire be well insulated. Silk-covered wire would be preferable. Avoid enameled wire if the enamel seems the least bit cracked or worn.

The "R-9'er" will work on 20 meters but it will be necessary to make several minor changes if optimum performance is to be realized. The first change should be to remove R_1 and R_5 from the circuit. These should be replaced in duplicate on the six and ten meter plug-in coils and wired directly across L_1 and L_2 . In other words, L_1 and L_2 on the ten meter coil should each have a 7,000 ohm resistor added in parallel to them. The six meter coil should be changed similarly.

It is necessary to make this change as the 20 meter coils will require a different resistance in parallel and it is necessary to remove the internal

resistance in order that the proper resistance will be added to the circuit automatically when coils are changed.

The 20 meter coil should be wound with 25 turns of very small wire. As explained before, this wire should be small enough to allow all 25 turns to be placed in one layer. The resistance to be added across the coil will now depend upon the Q of the coil in the circuit. For example, if the coil Q is 100, the resistance to be added across both coils should be 25,000 ohms. For a Q of 75, 36,000 ohms should be added. For a Q of 50, the resistance should be omitted entirely.

Inasmuch as very few of us will be able to measure the actual Q , it is suggested that the resistance be omitted entirely on the 20 meter coils. If the "R-9'er" then seems to be too sharp and covers too narrow a band, resistors should be added across L_1 and L_2 on the 20 meter coil until the band width is approximately 1 megacycle. The band width can be judged roughly by tuning the receiver across the band and listening for the slight amount of background noise which indicates that amplification is being achieved. When the increased background noise covers approximately one megacycle on the dial the band width may be considered to be approximately one megacycle. After resistors have been added which broaden out the band width to this value, the coils should be properly adjusted.

Another change that is suggested for operation on 20 meters is to make C_1 and C_6 10 mmf instead of 5 mmf. This change will give added sensitivity on 20 and will not affect operation on 6 or 10 meters appreciably.

With changes made as described above the "R-9'er" will give appreciable gain on the 20 meter band, although it will not be as great as that obtained on six and ten meters.—Lighthouse Larry.

WHY FORCED-AIR COOLING

Several of the tubes now being recommended for use in high-power ham rigs require forced-air cooling. Among these tubes are the GL-4D21/4-125A, the GL-5D24 and the GL-592. They require this extra cooling because this method of heat dissipation was designed into the tube. Forced-air cooled tubes represent the very latest in tube design. They are compact, allowing small, high-power rigs to be designed. Their compact size also permits thorough electrical bypassing, which in turn means less parasitic trouble and higher efficiencies. Bypassing of tube elements to ground is improved in any tube as the internal lead length is shortened. This is due to the decreased inductance of the internal lead, and to the fact that the bypass condenser is physically closer to the element inside the tube.

The only way to get short tube leads is to use a small bulb. This is where the forced-air cooling comes into the tube requirement. All tubes, regardless of type of cooling, must be designed to satisfactorily get rid of a certain amount of heat, which comes primarily from the filament and the anode. Many tubes dissipate this heat by radiation and convection, that is, the normal room air surrounding the tube absorbs the heat and carries it away.

Forced-air cooling, which consists of forcing air past a tube with a fan or a blower, becomes necessary when the tube envelope is not large enough to allow the heat to escape into still air. In other words, a GL-592 might not require forced-air cooling if it were made in a much larger bulb—say four or five times its present size. This large size tube would then have sufficient bulb area to dissipate its heat easily—but, the grid leads, filament leads and anode lead would now be so very long that operation on high frequencies (and efficient operation on lower frequencies) would be impossible. In other words, if you want an efficient high-power high-frequency transmitting tube, you must be prepared to use forced-air cooling.

In the case of the GL-592, forced-air cooling of 15 CFM (cubic feet per minute) is specified. This

relatively small amount of air can be obtained from an eight inch household fan mounted no farther than ten inches from the bulb of the tube. When full ICAS rating is desired, a finned anode connector is required. The eight inch fan will adequately cool a pair of GL-592 tubes.

Because the GL-592 tube uses no metal base, special cooling of the base is not necessary. In the case of the GL-4D21/4-125A and the GL-5D24, the metal base sufficiently restricts the flow of cooling air that it is necessary to provide special cooling for the base. For example, the GL-5D24 specifications call for 15 CFM on the envelope, and in addition require from 2 to 5 CFM through the base.

The exact amount of forced-air cooling required varies with the mechanical layout, and all figures quoted above are approximate. In general, the ham will want to provide more-than-sufficient cooling, unless he is able to experimentally determine the exact amount required.

If the use of forced-cooled tubes is contemplated, it is best to design the mechanical layout of the transmitter so that adequate ventilation is possible. If an enclosed rack is used, the fan may be mounted on the side of the rack itself, in a hole which is the same size as the fan. A similar hole can be cut in the opposite side of the rack to provide an exit for the air.

Blowers may also be used for cooling. Air ducts should be used to direct the air onto the tubes, as a blower does not put out a broad stream of air (like a fan) and it is necessary to channel the small stream of air directly onto the tubes.

Even though cooled by a fan, tubes of this sort do not run "cool," and it is still necessary to let them cool down before they can be handled. For example, the bulb of the GL-592, when properly cooled, should run at approximately 400°F—definitely above the "ouch" temperature.

The forced-air cooled tubes in the line of General Electric ham tubes include one triode, the GL-592, and two tetrodes, the GL-4D21/4-125A and the GL-5D24.—Lighthouse Larry.

QUESTIONS AND ANSWERS



Do you have any questions about tubes or tube circuits? Lighthouse Larry would like to answer them for you. For each question published you will receive \$10 worth of G-E electronic tubes. All questions not published will be answered promptly by mail. Send your questions to Lighthouse Larry, Tube Division, Bldg. 269, General Electric Company, Schenectady, New York, or in Canada, to Canadian General Electric Company, Ltd., Toronto, Ont.

Question: In consideration of tubes used in audio applications, and in Class B modulator service in particular, what is the resulting value of plate-to-plate load impedance when additional tubes are placed in parallel with the push-pull tubes? (Assume voltage remains the same.) Will the power output be doubled?—W4JJD.

Answer: The plate-to-plate load impedance for push-pull parallel Class B audio tubes will have a value of one-half the impedance of the load impedance of push-pull tubes. For example, two GL-805 tubes will have a load impedance of 8200 ohms at 1500 volts. Four GL-805 tubes in push-

pull parallel will have a load impedance of 4100 ohms. The power output will be doubled if additional driving power is available.—Lighthouse Larry.

Question: I have a radio using a 11Z6 rectifier tube. There is an initial surge of current which lights the heater beyond normal brilliancy when the set is first turned on. Does this momentary overload have any detrimental effect on the tube?—W6CBX.

Answer: The initial surge of current is caused by a very low filament resistance. As the filament becomes hot this resistance increases and the filament current becomes normal. Tubes of this sort are designed to operate in exactly this manner so that normal tube life may be expected.—Lighthouse Larry.



TRICKS AND TOPICS

UNIVERSAL CRYSTAL SOCKET

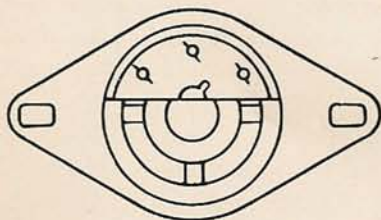

Fig. 7—W2MZ's Universal Crystal Socket

A number of hams like to use a group of crystals, selecting one or the other by means of a multi-contact switch. On the other hand, there are times when it is desirable to have but one crystal socket. Following is a description of a socket which will accept any common type of crystal holder.

All that is required is an octal socket, a five-prong socket, a hack saw and a file. The sockets should be of a type which are retained in the mounting flange or chassis by a warped spring, rather than molded into the flange. The five-prong socket is sawed through, close to pin holes 2 and 4. The piece of socket containing pin holes 2, 3 and 4

is retained. (See figure.) The octal socket is similarly cut, retaining a piece with any three pin holes. The two pieces are then trimmed smooth, made square, and fitted together until they will assemble in the flange as a unit, and be held tight by the socket spring.

The resulting socket can be wired so that it will handle either the small crystal holder with $\frac{1}{2}$ inch pin spacing, the larger holder with $\frac{3}{4}$ inch pin spacing, or the holder with $\frac{1}{2}$ inch pin spacing and large prongs. (This latter type fits into pins 2 and 3.)—W2MZ.

SOCKET WIRING TRICK

Here is a trick that I found to be very handy in my power supply. It comes in handy when a rectifier tube burns out and an exact replacement is not immediately available.

If the octal socket used for the rectifier tube is wired as follows, almost any rectifier tube may be used. Connect pins 3 and 4 together; 5 and 6 together. The high voltage connects to these two points. Connect pins 2 and 7. This is one filament connection and pin 8 is the other.

The following tubes will now work in this socket: 5R4-GY, 5T4, 5U4-G, 5V4-G, 5W4, 5W4-GT, 5X4, 5Y3-G, 5Y4-G, 5Z4, 5Z4-GT.—W3ITL.

TECHNICAL INFORMATION

GL-8000 Outline

GENERAL

Electrical Data

Filament Voltage (A-c or D-c).....	10 Volts
Filament Current.....	4.5 Amperes
Amplification Factor.....	16.5
Direct Interelectrode Capacitances, approximate	
Grid-Plate.....	6.4 uuf
Grid-Filament.....	5.0 uuf
Plate-Filament.....	3.3 uuf

MAXIMUM RATINGS AND TYPICAL OPERATING CONDITIONS

Radio-frequency Power Amplifier and Oscillator—Class C Telegraphy. Key-down conditions per tube without modulation

Typical Operation	CCS	ICAS
D-c Plate Voltage.....	2000	2500 Volts
D-c Grid Voltage		
From a fixed supply of.....	-195	-240 Volts
From a grid resistor of.....	8100	6000 Ohms
From a cathode resistor of.....	710	700 Ohms
Peak R-f Grid Voltage.....	370	480 Volts
D-c Plate Current.....	250	300 Milliampers
D-c Grid Current, approximate.....	24	40 Milliampers
Driving Power, approximate.....	.8	18 Watts
Power Output, approximate.....	375	575 Watts

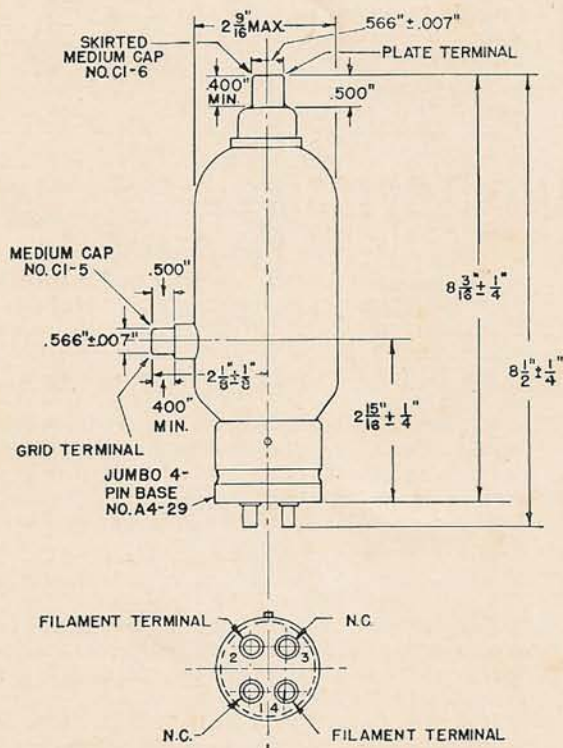

The GL-8000 is a three-electrode tube designed for use as a power amplifier, modulator, and oscillator. The anode is capable of dissipating 175 watts, and cooling is accomplished by radiation. The cathode is a thoriated-tungsten filament. Maximum ratings apply up to 30 megacycles.

CQ CQ Here's an angle for you when working DX south of the border. If "Megatroncito" is mentioned—it's Spanish for

Lighthouse Larry

Electronics Department

GENERAL ELECTRIC

Schenectady, N. Y.

(In Canada, Canadian General Electric Company, Ltd; Toronto, Ont.)