



# HAM NEWS

TUBES

JANUARY-FEBRUARY, 1962

## THE LWM-3

### A BANDSWITCHING SSB MOBILE TRANSCEIVER PART II—MECHANICAL DETAILS

By W. C. Louden, W8WFH, and A. F. Prescott, W8DLD

*PART II of the LWM-3 transceiver article covers the complete mechanical and constructional details. Also described is the procedure for initial alignment of all circuits requiring it, and the tuneup for normal operation of the transceiver once adjustment is completed. The LWM-3 as described by W8WFH and W8DLD is a compact neat package of advanced electronic circuitry that is ideal for both mobile and home-station operation. Also, W8WFH's model has a single main chassis plate; amateurs who duplicate the LWM-3 may prefer to utilize the various sections into subassemblies. This type of construction probably will result in a somewhat larger over-all size for the LWM-3, since extra space is needed where subassemblies join together. However, unitized construction is the option of the builder; the LWM-3 as described applies to the methods used by W8WFH on his model.*

#### LAYOUT

In positioning parts on the chassis, thought must be given to orienting the sockets so that short leads may be used to minimize stray coupling. Also the tube sockets should be located to allow the arrangement of the circuit components about them. The socket locations shown in the chassis layout diagram, Fig. 7, were selected for these reasons and, also, as mentioned in Part I of this article, to allow the location of the much-used controls on the left side of the panel near the operator in the driver's seat.

Those tubes such as the mixers which use common VFO and crystal RF voltages are mounted adjacent to one another. The 6BZ6 RF amplifier ( $V_6$ ) is located so as to permit short leads to the slug-tuned coils ( $L_{200}$  and  $L_{210}$ ). The first crystal oscillator tube ( $V_{10}$ ) is located to minimize lead lengths to the crystal switching sections of the bandswitch ( $S_2$ ). The same basic idea is carried throughout the entire chassis layout.

It is recommended that the given chassis layout be used as a minimum of stray coupling difficulties was encountered with it.

#### CHASSIS AND CABINET CONSTRUCTION

The chassis was constructed of  $\frac{3}{8}$ -inch thick aluminum to provide a rugged mounting for the parts. It is desirable to use this heavy material for two reasons: 1) It can be drilled and tapped for mounting parts; and 2) It will not flex to any great extent and thus deform the VFO and cause frequency shift.

Holes are punched in the chassis while it is still a flat sheet, using the chassis layout diagram, Fig. 7, as a guide. Although hand punches and drills can be used, a punching machine, if available, saves hours of building time. Flanges  $\frac{1}{2}$ -inch wide are then formed on all four sides with a sheet metal brake. The front and back edges were bent up and the two sides bent down. The small edges were used rather than a standard chassis design to facilitate the mounting of the many small parts. The builder may then work not only from the bottom of the chassis but also from the edges. (Continued on page 2)

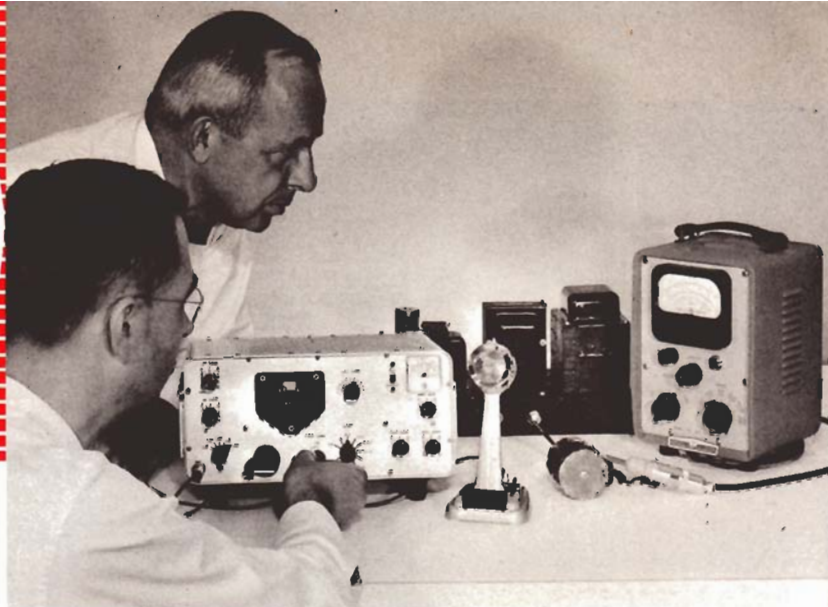

W8WFH (front) and W8DLD run power output tests on the completed LWM-3 SSB/CW transceiver, running it into a 50-ohm dummy antenna load. Vacuum-tube voltmeter is measuring RF voltage across load, providing power output indication.

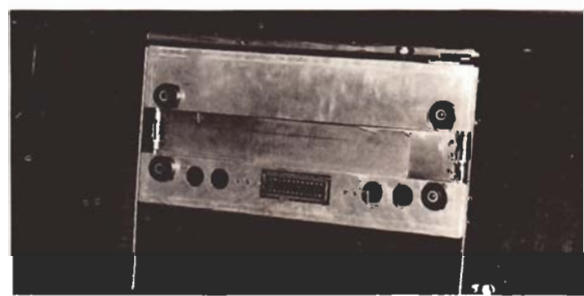

**MOUNTING RACK** for mobile operation of the LWM-3 transceiver in W8WFH's car. Hinged mounting arms (open in top view) slip into "pockets" on each side of LWM-3 cabinet, providing "slip in — slip out" removal of transceiver from car, and shock-resistant mounting. Arms fold (lower view) out of way of center passenger in front seat when LWM-3 is removed. All power and control connections to LWM-3 are made through 24-pin jack in middle of rack, matching similar type plug on rear of cabinet. Meters and indicator lights above transceiver mounting rack show performance of 3-phase AC mobile power system.

## IN THIS ISSUE

THE LWM-3 — PART II — CONSTRUCTIONAL DETAILS.....	page 1
Three GE Amateur Handbooks Now Available.....	page 7
More G-E Compactron Devices announced.....	page 8



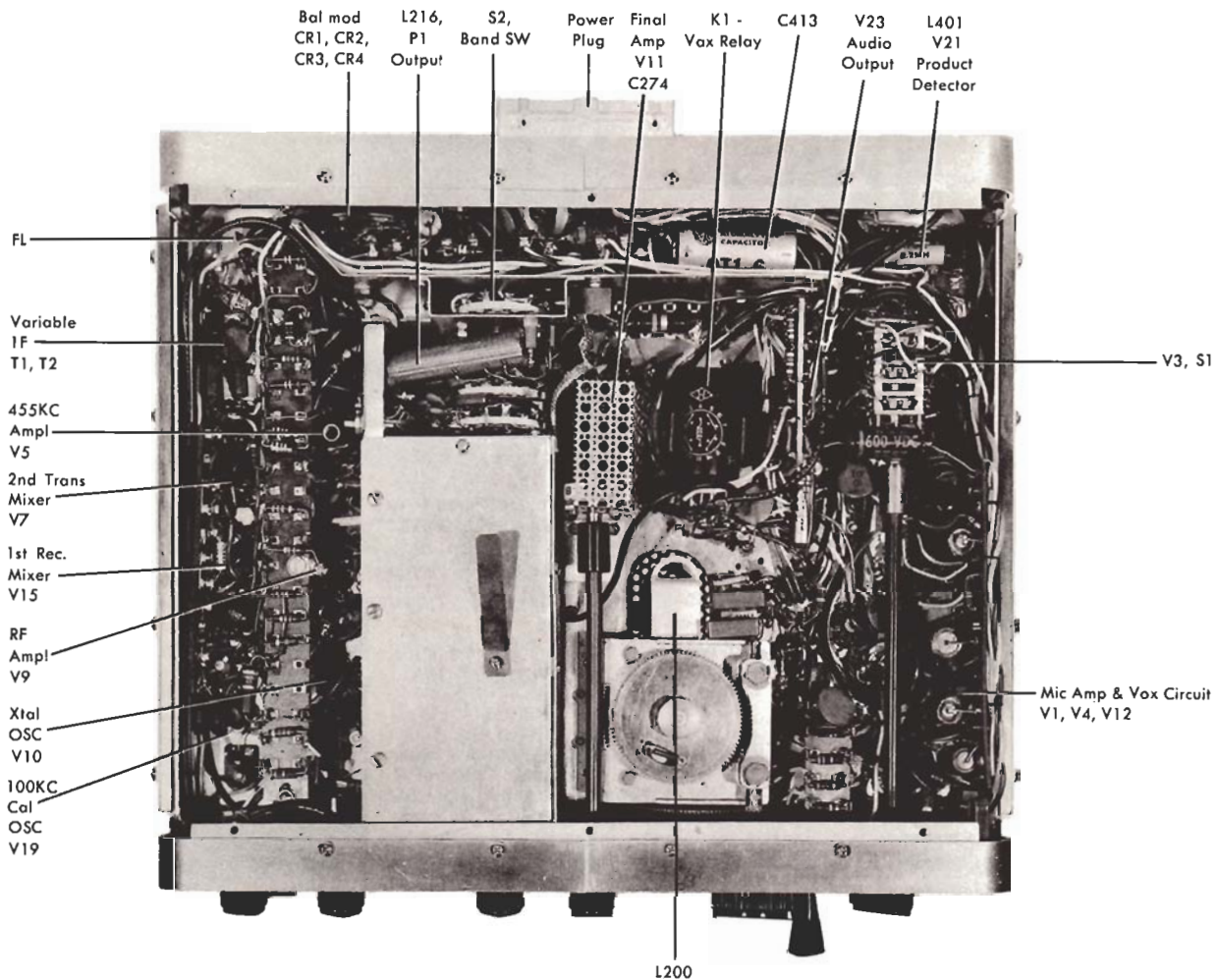

**BOTTOM VIEW OF THE LWM-3, showing the over-all assembly.** Covered section contains coils L<sub>208</sub> and L<sub>209</sub>, plus all of the trimmer capacitors and bandswitch sections (S<sub>2C</sub> and S<sub>2D</sub>) associated with these tuned circuits in the RF amplifier/driver stage (V<sub>9</sub>). MODE SELECTOR switch (S<sub>1</sub>) is in upper right corner. Transmitter and SSB

generator sections are at left. Audio and VOX section is in right front corner, and receiver section runs along rear of chassis. Most small components — except RF bypass capacitors, which are mounted directly on tube sockets — have been mounted on narrow terminal boards as subassemblies for maximum rigidity and compactness.



presents **HOW-TO-DO-IT IDEAS**  
from the 999 radio amateurs at

**GENERAL ELECTRIC**

A bi-monthly publication of the RECEIVING TUBE DEPARTMENT  
Owensboro, Kentucky, U. S. A. • Editor — E. A. Neal, W4ITC

G-E HAM NEWS is available free from authorized G-E Tube distributors. Some distributors mail copies locally to their customers.

A low-cost direct-mail subscription plan is available to persons residing in the United States and its possessions (including APO and FPO numbers).

Subscription rates are:  
 One Year (6 issues).....\$1.00  
 Two Years (12 issues).....\$2.00  
 Three Years (18 issues).....\$3.00  
 Five Years (30 issues).....\$4.00

Enclose check or money order for U. S. currency for the proper amount above made payable to "General Electric Company."

Residents of Canada may subscribe to G-E HAM NEWS for \$1.00 per year from the Canadian General Electric Company, Ltd., Electronic Tube Marketing Section, 189 Dufferin Street, Toronto 3, Ontario,

Canada. Enclose check or money order made payable to: "Canadian General Electric Company, Ltd."

Distribution of G-E HAM NEWS in more than 40 foreign countries is handled through the International General Electric Company. A listing of outlets is available from the G-E HAM NEWS office. Or, write to: Customer Inquiry Section, International General Electric Company, 159 Madison Avenue, New York 16, New York, U. S. A.

**NOTE:** The disclosure of any information or arrangements herein conveys no license under any patents of General Electric Company or others. In the absence of an express written agreement to the contrary, the General Electric Company assumes no liability for patent infringement (or any other liability) arising from the use of such information by others.

**THE LWM-3** (Continued from page 1)

The sides, front and back panels are screwed to the chassis with 4-40 x 1/4-inch long machine screws. During preliminary debugging of the transceiver the sides and back were removed. A dummy front panel was used to support the controls. After the circuits are working properly, the sides, front and back panels are screwed into place.

The over-all size and constructional details of the cabinet are shown in Fig. 8. The curved shapes of the four corners of the perforated aluminum cabinet were formed by carefully bending the metal around a 1-inch wood dowel. The metal was clamped between the dowel and a wood bench top and bent first by hand. The curve was then smoothed with a plastic mallet.

The 3/4 x 1/8-inch aluminum strips which form the front and back lips of the cabinet were formed in the same manner. The strip was first cut longer than necessary and trimmed after forming without a gap at the junction of the two ends. Small aluminum angle strips were made from 1/8-inch sheet

stock to fasten the strips to the front and back panels and to provide an edge for fastening the perforated covers. The complete cabinet assembly was fastened together with Phillips head 4-40 x 1/4-inch long machine screws.

The front panel should next be fitted to the cabinet and then punched and drilled for the various controls as shown in Fig. 9. The dial opening may be cut with 1 1/4-inch diameter socket hole punches at the corners, then sawing between these holes. A half-round file is used to smooth the edges.

The dial escutcheon is made from 1/4-inch thick aluminum, drilled and filed to shape as shown in Fig. 10. It was then painted with flat black lacquer. Assembly details of the dial plate and dial cover are shown in Fig. 11. A command set transmitter dial plate is cut down to 2 inches in diameter, and a disc of 1/8-inch thick clear lucite plastic is riveted to it.

The dial cover also is of 1/8-inch clear plastic. Note in the dial detail photo on page 6 that the dial cover is fastened to the escutcheon with a 6-32 machine screw. A simple zero-adjustment is made by using a small "wire nut" as a knob on the front of the dial escutcheon. A 1/4-inch diameter rubber grommet is fastened to the wire nut with a flat-head machine screw. The grommet then drives the rim of the dial cover and thus moves the hairline.

### CIRCUIT WIRING

Construction should begin with the packaged VFO unit. The VFO should oscillate with satisfactory frequency stability before proceeding further with construction. All frequency determining components — L<sub>200</sub>, L<sub>201</sub>, C<sub>212</sub>, C<sub>203</sub>, and C<sub>204</sub> — are mounted directly on the frame of the oscillator tuning capacitor (C<sub>215</sub>), as shown in the top and bottom views. The command transmitter tuning capacitor selected was from a 2.1-3 Mc Navy T19/ARC-5. The capacitor has the gear reduction and dial mechanism mounted on its frame.

It had 16 rotor plates originally, but 6 plates were removed to allow the VFO to tune from 2.5 to 2.7 megacycles. Start by removing only 4 plates, and additional plates may be removed as desired to cover the proper range. The capacitor is mounted with solid brackets to the chassis, one on each side. Each is 2 inches wide and is fastened with two 6-32 screws to the chassis at one end and two to the capacitor at the other end. Do not allow the tuning shaft to rub the panel, or any other intermittent grounds to occur, as this may cause a small frequency shift in the VFO when the unit is subjected to vibration.

The RF amplifier (V<sub>5</sub>) and high frequency (V<sub>10</sub>) crystal oscillator are completed next. The band switch and slug tuned coil layout will depend upon the mechanism used to move the tuning slugs. The permeability tuning and push-button head from an old auto radio is used to move the tuning slugs in L<sub>206</sub> and L<sub>209</sub>. This one was from a Delco radio, vintage about 1952. However, other model auto receivers have similar units. All parts were removed except the bracket which contains the bearings and the bar and shaft which move the slugs. The ladder-like appearance of the unit was the original mounting for the push buttons.

(Continued on page 4)

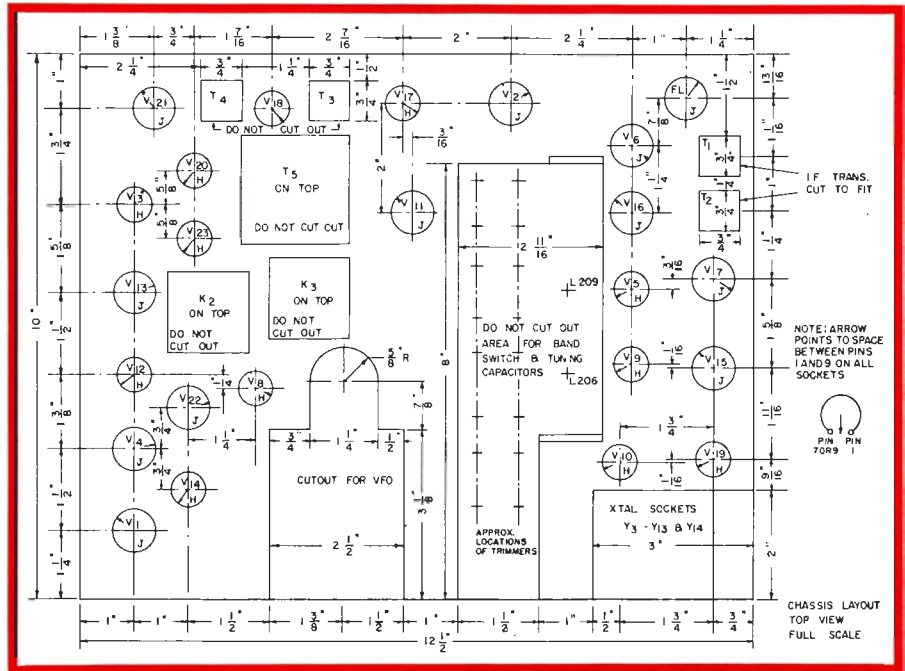
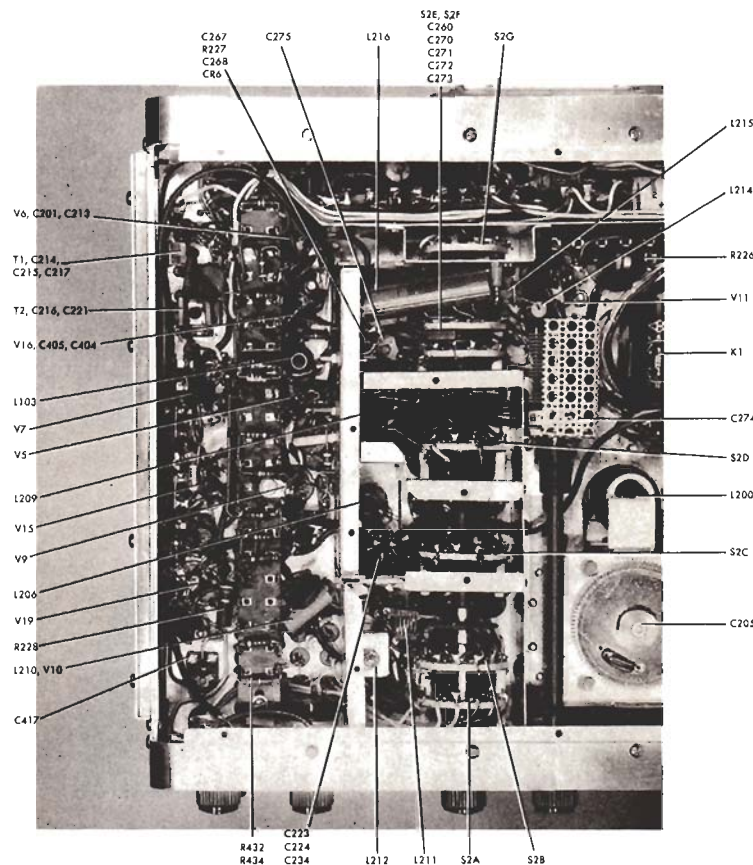

FIG. 7. CHASSIS LAYOUT DIAGRAM for the LWM-3 transceiver as constructed by WBWFH. Material is 3/32-inch thick sheet aluminum. Precise locations of the small trimmer capacitors will depend on the size of the slug mechanism. Position of the blank on each tube socket is indicated by the arrow. A 9-pin miniature tube socket is required only for a Collins "J" type filter (right rear corner). Type "E," "F" and "Y" filters require other mounting means.<sup>3</sup>



BANDSWITCH SECTION OF LWM-3 showing, front to back, the crystal oscillator (V<sub>1</sub>), RF amplifier/driver (V<sub>5</sub>), and output amplifier (V<sub>11</sub>) sections. Tubes and other circuit elements associated with the SSB generator and transmitter sections (upper half of block diagram, Fig. 1, on page 2 of November-December, 1961 issue) are located along the left hand edge of the chassis.



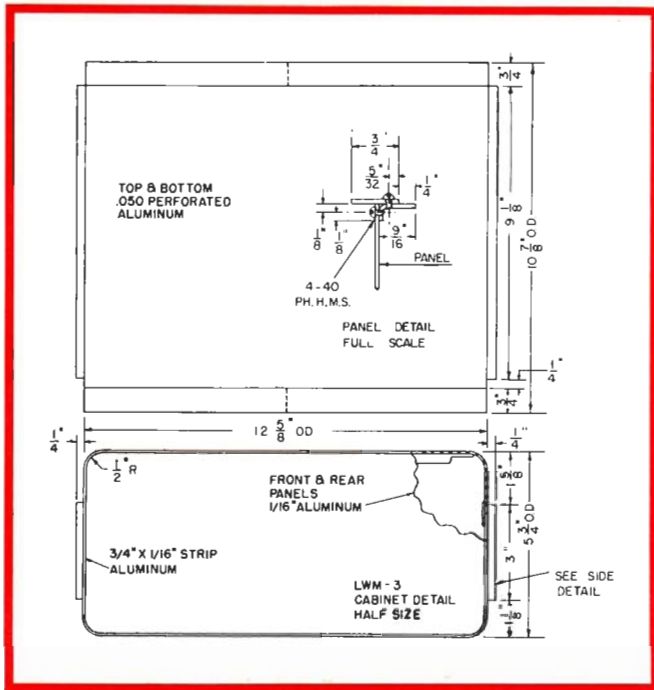

FIG. 8. CABINET ASSEMBLY DRAWING for a custom-made cabinet. Material is 1/32-inch perforated aluminum sheet. Front and rear lips are 3/4 x 1/8-inch thick aluminum strip. Do-it-yourself aluminum, available in hardware stores, was used.

OUTPUT BAND, MC.	BANDSWITCH POSITION	CRYSTAL FREQUENCY, MC.	CRYSTAL OUTPUT FREQUENCY, MC.
# 3.4 — 3.6	1 & 2	6.555	6.555
# 3.5 — 3.7	1 & 2	6.655	6.655
# 3.6 — 3.8	1 & 2	6.755	6.755
# 3.8 — 4.0	1 & 2	6.955	6.955
# 7.0 — 7.2	3	10.155	10.155
# 7.1 — 7.3	3	10.255	10.255
# 7.2 — 7.4	3	10.355	10.355
#14.0 — 14.2	4 & 5	8.5775	17.155
#14.15 — 14.35	4 & 5	8.6525	17.305
14.2 — 14.4	4 & 5	8.6775	17.355
15.0* — 15.2	4 & 5	9.0775	18.155
#21.0 — 21.2	6 & 7	12.0775	24.155
21.2 — 21.4	6 & 7	12.1775	24.355
#21.25 — 21.45	6 & 7	12.2275	24.455
21.4 — 21.6	6 & 7	12.2775	24.555
#28.0 — 28.2	8 thru 11	15.5775	31.155
28.2 — 28.4	8 thru 11	15.6775	31.355
28.4 — 28.6	8 thru 11	15.7775	31.555
#28.5 — 28.7	8 thru 11	15.8275	31.655
#28.7 — 28.9	8 thru 11	15.9275	31.855
#28.9 — 29.1	8 thru 11	16.0275	32.055
#29.1 — 29.3	8 thru 11	16.1275	32.255
29.3 — 29.5	8 thru 11	16.2275	32.455
29.5 — 29.7	8 thru 11	16.3275	32.655

\*Only for reception of WWV! #Recommended ranges.

**THE LWM-3** (Continued from page 3)

The small ceramic trimmer capacitors in the grid and plate circuits of  $V_0$  are mounted in a compact grouping to minimize lead lengths and space required for the tuner. Extensive shielding is used between grid and plate sections of the switch and between the RF amplifier and other circuits, the crystal oscillator on one side and the final amplifier on the other. A 1/4-inch fibre shaft is filed down and substituted for the original metal shaft in switch sections  $S_{2c}$  to  $S_{2g}$ . It is driven from switch  $S_{2B}$  with a flexible coupling.

The remainder of the receiver is then

wired and the receiver tested as a unit (see alignment and tune-up procedure).

The transmitter is started by wiring the audio amplifier and vox circuit. This unit may be tested separately through the use of the tone oscillator and, of course, with voice signals from a crystal microphone. A small 1000 to 200,000 ohm matching transformer is necessary with a controlled reluctance microphone (see page 1 of Part I) to obtain sufficient voltage to drive the audio system.

The BFO isolation amplifier and balanced modulator can now be completed; and, to facilitate testing, the

vox relay ( $K_1$ ) may either be tied closed, or the relay tube ( $V_{13B}$ ) biased to hold the relay closed.

The remainder of the transmitter circuits may be completed with the exception of the pi-network output capacitors ( $C_{28}$  to  $C_{23}$ ).

**CONSTRUCTION HINTS**

Subminax cable (Amphenol No. 21-598) was used to carry RF voltages around the chassis from tube to tube. This cable has good low loss insulation and is small in diameter. Lapel microphone shielded cable was used to carry the audio voltages to the various controls. Number 22 and 24 insulated hook-up wire is used for general circuit wiring. Small capacitors are essential to compact construction. Some circuits

**BOTTOM REAR VIEW**, showing the components in the receiver portion of the transceiver along the rear of the chassis. The back panel has been raised to reveal this section. Most small parts are mounted on two terminal boards which are fastened to a shield of 1/8-inch thick aluminum running across the chassis. Note the shield across the 9-pin miniature socket for the mechanical filter at the left.

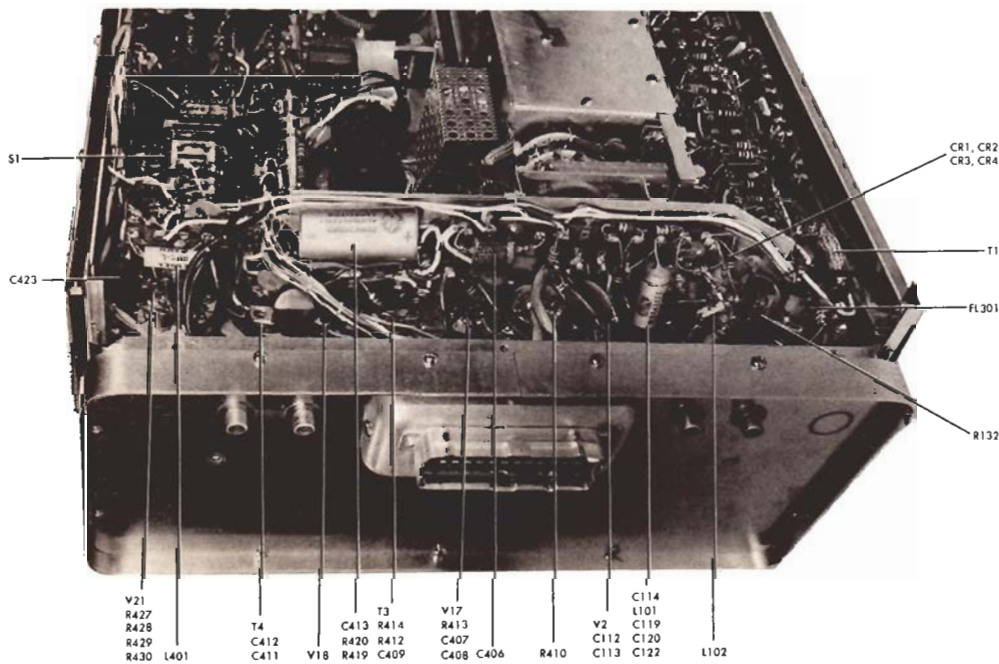

**FOOTNOTES—LWM-3**

<sup>1</sup>AVAILABILITY OF MECHANICAL FILTERS:  
The Collins F455J-21 mechanical filter used in the LWM-3 is available through authorized Collins distributors at \$57.50 each. Also available directly from Collins Radio are the F455E-21 and F455F-21 filters (horizontal type case with terminal on bottom) at \$43.00 each, F.O.B. factory.  
The F455Y-21 filter (small cylindrical type with terminals on ends, used in "S" line and KWM-2) is available both from the factory and authorized Collins distributors at \$50.75 each.  
For amateurs who prefer a 3.1-kilocycle bandwidth, a F455Y-31 filter is available directly from Collins Radio at \$38.00, F.O.B. factory. For this filter, use a 453.1-kilocycle crystal at  $Y_1$  and a 456.9-kilocycle crystal at  $Y_2$ .  
Order F455E-21, F455F-21 and F455Y-31 filters from Collins Radio Company, Components Division, 3324 West Warner Avenue, Santa Ana, Calif. Include remittance with order. This information was supplied by Collins Radio Co. Prices and availability are subject to change without notice.  
<sup>2</sup>Vector prepunched phenolic terminal boards and push-in terminals are listed on page 136 of 1962 catalog of Lafayette Radio Electronics, Inc. 111 Jericho Turnpike, Syosset, L. I., New York.  
<sup>3</sup>Detailed information for checking frequency drift of VFO's is given in the "Stabilized Master Oscillators" chapter of Fundamentals of Single Sideband, by Collins Radio Company.

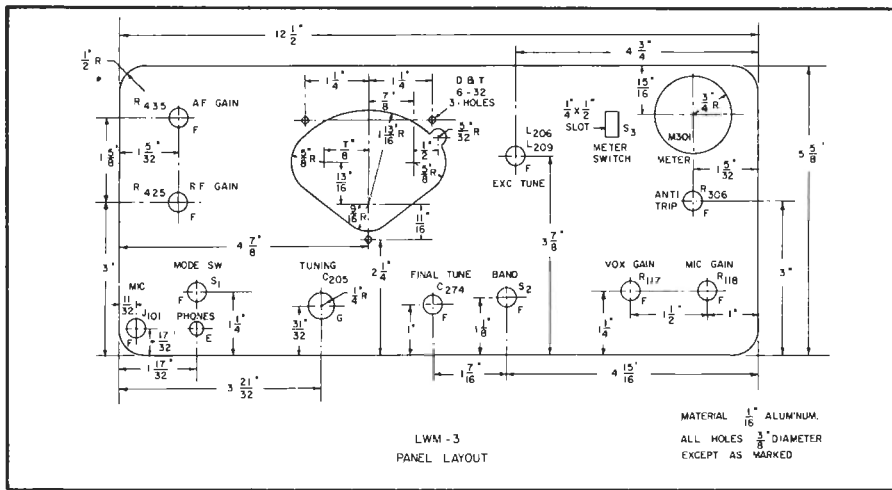

FIG. 9. PANEL LAYOUT DIAGRAM for the LWM-3 transceiver. The panel should not be drilled until locations of chassis components are finalized to avoid errors. The  $\frac{1}{16}$ -inch thick aluminum sheet can be left shiny, brushed, or etched to give the desired finish.

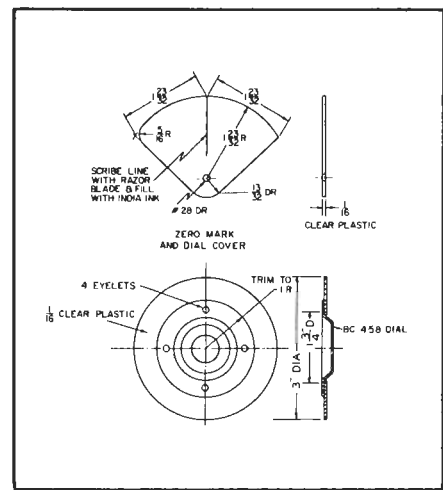

FIG. 11. DETAIL DRAWING of the dial cover and dial plate. The plate is made from a Command Set transmitter dial plate cut down to 2 inches in diameter to form a hub.

### HOLE SIZE CHART

- "E" drill— $\frac{9}{32}$ -inch diameter.
- "F" drill— $\frac{3}{8}$ -inch diameter.
- "G" drill— $\frac{1}{2}$ -inch diameter.
- "H" socket punch— $\frac{5}{8}$ -inch diameter for 7-pin miniature tube socket.
- "J" socket punch— $\frac{3}{4}$ -inch diameter for 9-pin miniature tube socket.

were rebuilt a number of times as smaller components became available.

The perforated circuit board was found to be one of the most convenient and compact methods of mounting parts. The Alden Products Co. of 185 North Main Street, Brockton, Mass., and Lafayette Radio Electronics<sup>1</sup> both sell them. Small terminals for use with the boards may be purchased also; however, brass eyelets were set into the holes with a punch in a drill press. Some preliminary thought must be given to the layout of parts. However, all circuit soldering is done in the open.

Parts are mounted on one side and all wiring is done on the other; pigtailed are provided on the board for connection to the tube sockets. It is a good idea

to include a few extra terminals or eyelets on the board for last-minute changes, as it's more difficult to insert these after the board is in place. Small boards made in this manner were used to hold small parts for the output RF voltmeter circuit parts, and the input circuit capacitors for the RF amplifier. These were mounted in place by a single 6-32 stud, as shown in the bottom detail views.

### ALIGNMENT AND TUNE-UP PROCEDURE

When preliminary work is being done on the VFO its output can be monitored using a separate receiver. For stability checks the fifth harmonic or higher should be used to quickly detect drift or frequency shift due to shock and vibration.<sup>2</sup>

The VFO dial can be calibrated from 0 to 200 by using a separate monitoring receiver and a 100-kilocycle crystal calibrator. If a calibrator with a 10-kilocycle divider is available, the 10-kilocycle divisions can be marked on the dial plate with a pencil, and the 5-kilocycle points added midway between them. By using harmonics of the

VFO and monitoring then at higher frequencies, say 25 to 27 megacycles, 1-kilocycle calibration lines can be obtained. Five-kilocycle dial markings were found to be adequate on this model. Accurate initial calibration of the VFO dial will pay off later in good frequency resetability.

After marking the calibration lines on the dial plate, they can be scribed in and filled with black ink. Or, "Chart-Pak" cellulose tape may be used for the lines. Black decals are used for the numbers. After the dial plate is complete, spray it with a coat of clear lacquer to preserve the calibrations.

If a Collins "S" line receiver or transmitter, or KWM-2 transceiver, is available, the VFO in it can be used as a calibration source for the VFO in the LWM-3. Simply set the Collins gear dial to the 5-kilocycle intervals, starting at 2.5 megacycles, pick up the signal in a monitoring receiver, set the LWM-3 VFO to zero beat with it, and mark the calibrations on the dial.

The crystal oscillator can also be checked in the same manner as the VFO. A grid dip meter was used first (Continued on page 6)

FIG. 10. DIAL ESCUTCHEON drawing for the LWM-3. Corners and dial opening are rounded with a file to desired contours before painting. The three mounting holes are counterbored to allow flat head machine screws to be flush with the surface.

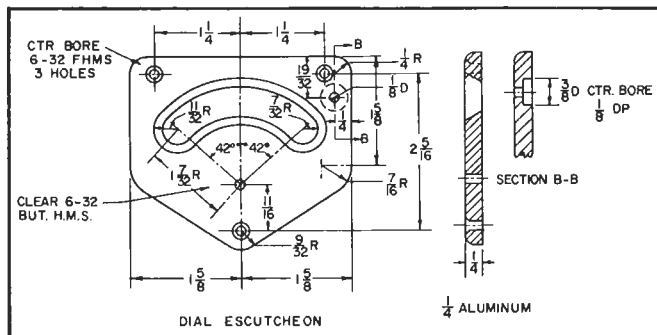
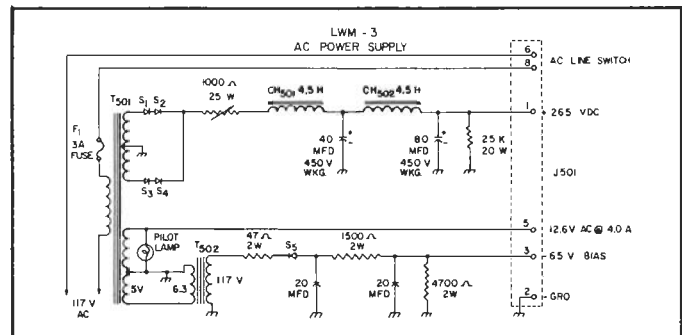
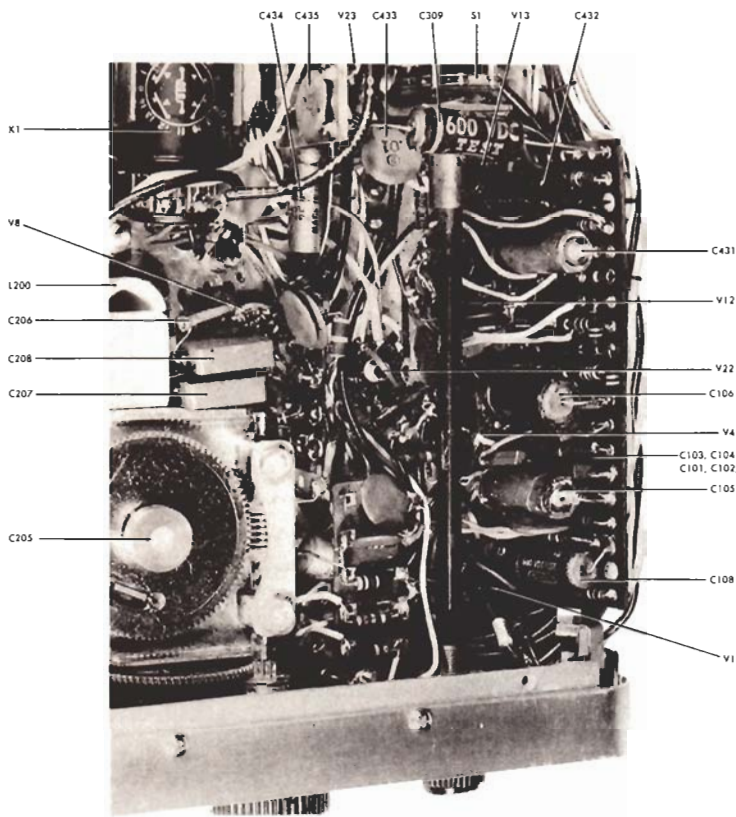

FIG. 12. AC POWER SUPPLY circuit for the LWM-3 transceiver. Chokes CH<sub>501</sub> and CH<sub>502</sub> are 4.5 henries at 200-milliamperes (Stancor C-1411). CR<sub>501</sub> to CR<sub>505</sub> are 600-PIV, 600-milliampere silicon rectifiers (G. E. IN1697). CR<sub>505</sub> is a 200-PIV, 600-milliampere rectifier. T<sub>501</sub> has a 580-volt center-tapped winding at 240 milliamperes; with 5-volt, 3-ampere, and 12.6-volt, 5-ampere heater windings, 117-volt primary (Stancor P-8352). A power transformer with two 6.3-volt, 5-ampere heater windings may be used by connecting these windings in series. T<sub>502</sub> is a 6.3-volt, 1-ampere filament transformer. For mobile work, a 250-volt, 250-milliampere DC power supply is required. Heater voltage is obtained from the 12-volt auto supply.







**AUDIO/VOX SECTION** of the transceiver. Most capacitors and resistors are fastened to the large terminal board at the right. The small terminal board in the center contains components for the AVC and S-meter circuits. The worm gear capacitor drive, and the reduction gear train for the tuning dial, are from a Command Set Transmitter. Capacitance range is about 10 to 60 mmf.

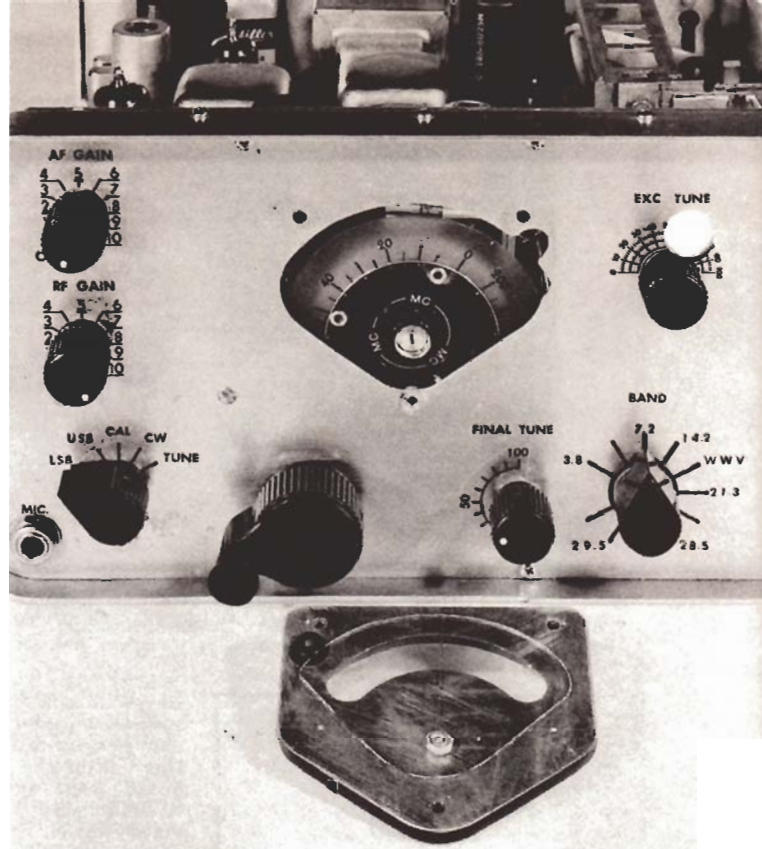

**DIAL PLATE** and escutcheon details are shown in this view. Dial plate rotates about 350 degrees for 180-degree rotation of tuning capacitor. Black decals are used to mark 0—200 on dial plate, identification of panel controls and their positions. Rubber grommet drives the edge of dial plastic dial cover for adjustment of calibration line at 100-kilocycle calibration points.

### THE LWM-3 (Continued from page 5)

to arrive at the proper coil and capacitor settings in the oscillator tuned plate circuits, especially when using the 2nd harmonic of the crystal frequency for 14, 21 and 28 megacycles.

When the receiver wiring is completed a 455-kilocycle signal is connected to pin 1 of  $V_{17}$ , a bias battery of  $-3V$  is connected from ground to the junction of  $C_{408}$  and  $R_{409}$ , and the IF transformers  $T_3$  and  $T_4$  roughly tuned to provide maximum output. The signal generator is then connected to the plate of  $V_{16}$  and adjusted until some signal can be heard through the IF strip. At this frequency  $T_3$  and  $T_4$  are readjusted to give maximum output.

The signal generator is then connected to pin 7 of  $V_{15}$  and set for 3 megacycles. Transformer  $T_1$  is adjusted roughly for maximum output. The input is then changed to both 2.96 and 3.15 megacycles, and  $T_1$  is adjusted to give a uniform response over this frequency band.

Next, select the desired 200-kilocycle tuning ranges from TABLE III — CRYSTAL CHART. Obtain crystals of the specified frequencies and plug them into the proper crystal sockets as indicated in the chart. Connect the signal generator to the antenna input jack ( $J_1$ ) and tune the VFO dial to 100.

Start with the highest frequency range to be covered — usually 29.5 to 29.7 megacycles — insert the 16.3275-megacycle crystal into the socket for position 11 of the bandswitch ( $S_2$ ). Set the signal generator to about 29.6 megacycles so that its signal is heard in

the LWM-3. Rotate the EXCITER TUNE control to maximum signal strength. Next, adjust the tuning slugs in both  $L_{206}$  and  $L_{207}$  until a signal peak is heard with the slugs pulled nearly out of the coils by the slug actuator mechanism. This adjustment assures close tracking of these circuits over 28.0 to 29.7-megacycle range (positions 8 to 11).

Next, set the bandswitch to position 6 or 7, and the tuning dial and signal generator to 21.3 megacycles. Adjust trimmer  $C_{226}$  and  $C_{239}$  for maximum signal after first peaking the signal with the EXCITER TUNE control. Then turn to position 4 and set the VFO and signal generator to 14.2 megacycles. Peak the EXCITER TUNE control and trimmers  $C_{228}$  and  $C_{241}$ . Repeat this procedure in position 3 at 7.2 megacycles, peaking EXCITER TUNE and  $C_{230}$  and  $C_{212}$ . Finally, align these circuits in position 1 at 3.8 megacycles, using EXCITER TUNE, and  $C_{222}$  and  $C_{244}$ .

The received signal is maintained at the same dial calibration point, when switching from lower sideband to upper, by switching the VFO frequency through the use of diode  $CR_5$  and capacitor  $C_{210}$ , at the same time the BFO frequency is switched. Pick up an AM station near the center of the dial range and tune so that the carrier is no longer heard. Switch  $S_1$  is then changed from LSB to USB and  $C_{210}$  is adjusted until either sideband can be heard without hearing the carrier frequency shift. The calibration of the VFO may be re-adjusted slightly with  $C_{203}$  to compensate for the slight change caused by the adjustment of  $C_{210}$ .

With the transmitter completed  $S_1$  may be turned to "tune" and, with microphone gain at zero and the vox gain at maximum, the transmitter will be keyed on but with no modulation. The remaining carrier can be detected with a separate receiver which has an S meter. Avoiding overloading the receiver,  $R_{132}$  and  $C_{122}$  are then adjusted to null out the carrier. If everything is working properly, the separate receiver can be connected to the transmitter output and, with maximum receiver gain, adjust  $R_{132}$  and  $C_{122}$  until the S meter reading is 3-4 S units. At this point if the separate receiver is tuned through the signal there will be no well-defined signal, just some noise.

With the carrier nulled out the microphone gain is increased slightly to provide some drive. A 50-ohm dummy load should be connected to the output jack ( $J_2$ ), and the RF voltage envelope from the LWM-3 can be viewed on an oscilloscope, or measured with a VTVM with an RF probe. The EXCITER TUNE control is rotated to give maximum output and  $L_{103}$  and  $T_2$  are adjusted for maximum output. The neutralizing control  $C_{275}$  should be adjusted in the usual manner on 21.4 or 28.5 megacycles with no drive applied to  $V_{11}$ .

For the final adjustment of the pi-network output capacitors,  $C_{269}$  to  $C_{273}$ , it would be well to connect the coaxial line and linear amplifier to be driven by the LWM-3 transmitter. Different values of capacitance can then be tried on each band to provide maximum drive at the linear amplifier under actual operating conditions.

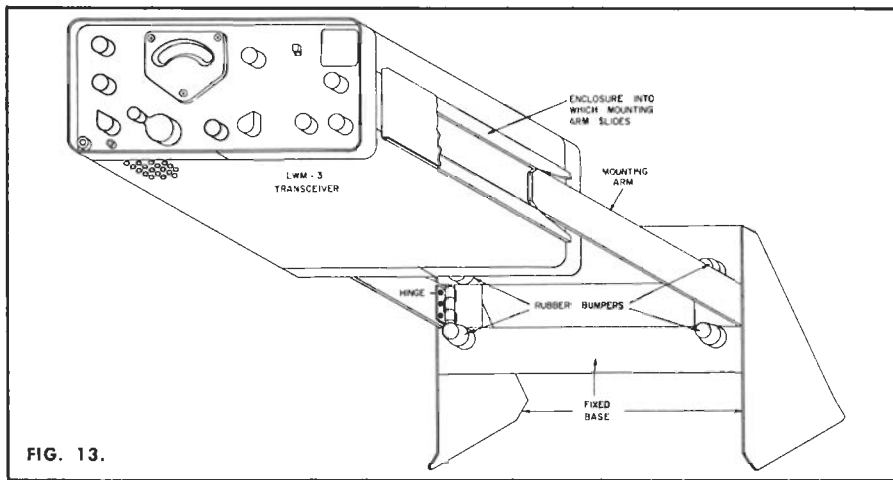

FIG. 13.

**MOBILE MOUNTING RACK** used by W8WFH for his LWM-3 transceiver. Vertical brackets and cross member are sheet aluminum at least  $\frac{3}{32}$  of an inch thick. Mounting arms are  $\frac{1}{8}$ -inch thick aluminum  $10\frac{1}{4}$  inches long and  $1\frac{3}{4}$  inches wide. Standard  $2\frac{1}{2}$ -inch butt type hinges are used to allow the mounting arms to fold flat when the mount is not in use (see photos on page 1).

### OPERATION

The band switch is set to the desired 200-kilocycles segment of the band. The **EXCITER TUNE** control is rotated to provide maximum received signal as indicated by the S Meter. The switch S<sub>1</sub> may be turned to the CAL position to check 100-kilocycle points from the crystal calibrator. Before transmitting turn S<sub>1</sub> to TUNE and the meter switch to OUTPUT. Adjust the FINAL TUNE capacitor for maximum meter indication and you are ready to call in on your favorite frequency. W8WFH has a switch on the dash of the mobile that allows this tuning to be done with the linear amplifier plate voltage off. In this manner no QRM is caused on the frequency before the LWM-3 is ready to operate.

The LWM-3 can also be connected directly to the antenna through a separate transfer switch. At one watt into the antenna W8WFH has been able to

maintain a contact from Chicago to New York on 7205 kilocycles. The main advantage of the low power, however, is to talk over very short distances, mobile to mobile, with no receiver overloading difficulties, or unnecessary QRM.

W8WFH devoted over a year and a half to designing, constructing and thoroughly testing his model of the LWM-3 before considering it complete. The experienced constructor should be able to duplicate it in from one to three months, depending upon the amount of "spare time" which can be devoted to this project.

However, the completed LWM-3 transceiver delivers performance comparable to fine commercial equipment costing several times the \$100.00 to \$250.00 in parts (depending on the extensiveness of your *junk box*) required. Moreover, the LWM-3 is a literal "gold mine" of design, circuit, mechanical and constructional ideas.

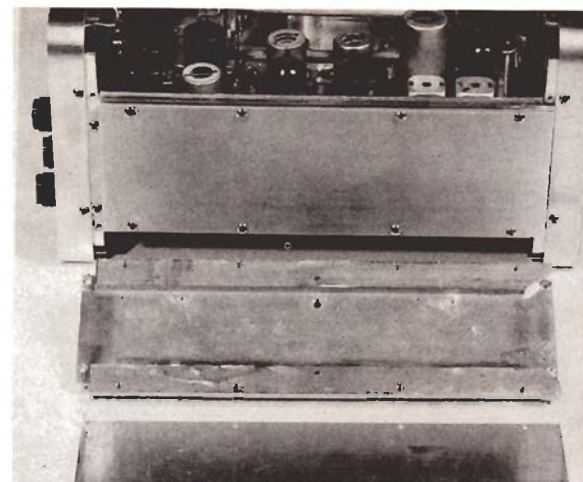

"SIDE POCKETS" on LWM-3 cabinet for mobile rack mounting arms (see Fig. 13 and photos on page 1) are made by sandwiching two spacer strips of  $\frac{5}{8} \times \frac{3}{16}$ -inch bar aluminum 9 inches long between  $\frac{1}{8}$ -inch thick aluminum plates 9 inches long and 3 inches wide. Position spacers and add thin shims so that mounting arms in rack slide freely into pockets without binding. Assemble pieces with 4-40 machine screws.

Nearly every amateur will find some feature that he can apply to his own equipment.

The packaged VFO unit, especially, utilizes the excellent tuning capacitor, worm gear knob shaft drive, and split-gear tuning dial drive from the command set transmitter. It can be adapted to practically any VFO circuit design — series and parallel-tuned high-C Colpitts, Hartley, Franklin, Vacker, etc. — and all popular amateur band tuning ranges.

Finally, the LWM-3 offers conclusive proof that the technology of home-constructing amateur radio equipment is keeping pace with commercial equipment, and is not a "dying" art!

## THREE NEW G-E HAM NEWS HANDBOOKS NOW AVAILABLE

### THIRD BOUND VOLUME COVERING 1956 TO 1960

(Publication No. ETZ-2620)

#### FEATURES—

- Hard-bound cover with grey leatherette binding in black and orange.
- 260 pages of issues from January-February, 1956 (Vol. 11, No. 1), to November-December, 1960 (Vol. 15, No. 6).
- Includes the 80-page supplement book described at right bound into book.
- Only source of many original issues published from 1956 to 1960.
- Prices: \$3.00, postpaid, in U.S.A. and possessions; \$3.50 in Canada and other countries, postpaid.

### Lighthouse Larry's SIDEBAND HANDBOOK

(Publication No. ETZ-2973)

#### FEATURES—

- Embossed grey fiberboard covers with white plastic comb style binding.
- 232 pages of articles on single and double sideband, and related subjects from *G-E HAM NEWS*, plus added data:
- Hetrodyning, exciters, linear amplifiers, power supplies, receiving adapters, accessories, etc.
- An "anthology" of sideband articles.
- Prices: \$2.00, postpaid, in U.S.A. and possessions; \$2.50, postpaid, in Canada and other countries.

### SUPPLEMENT TO ISSUES JAN. 1956, TO DEC. 1960

(Publication No. ETZ-2911)

#### FEATURES—

- Embossed grey fiberboard covers with white plastic comb type binding.
- 80 pages of added circuit, construction and tune-up data for original articles published in 1956 to 1960.
- Complete Cross Index of all articles from May-June, 1946 (Vol. 1, No. 1), to November-December, 1960 issues.
- Prices: \$1.00, postpaid, in U.S.A. and possessions; \$1.50, postpaid, in Canada and other countries.

### ORDERING INSTRUCTIONS FOR THESE PUBLICATIONS —

Send your order, and include proper remittance, made payable to "General Electric Company," to the address on

page 2 which serves your country. All three books are approximately  $6\frac{1}{2} \times 9\frac{1}{4}$  inches in over-all size.

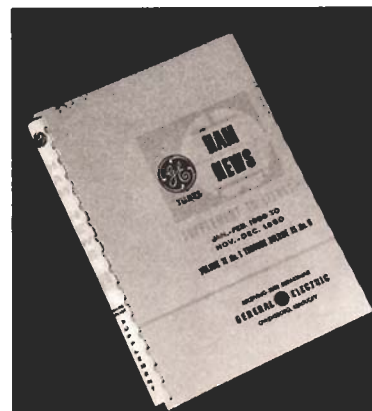



# MORE G-E COMPACTRON DEVICES ANNOUNCED

**SIXTEEN TYPES** of General Electric's COMPACTRON multi-function devices are now being supplied to manufacturers of electronic equipment. They are appearing in new television and home radio receivers, Hi-Fi amplifiers, and even in amateur radio gear. The new Hammarlund HX-50 SSB exciter has 6C10 and 6D10 triodes in it.

A typical short wave receiver requires about one-third fewer of the versatile Compactron devices than con-

ventional receiving tubes. In addition, they cost less per function.

Basic specifications of the sixteen types are given below. Note that up to four circuit functions can be performed by Compactron devices having combinations of diodes, triodes and pentodes. *G-E HAM NEWS* will publish additional data — and circuits too — as more Compactron devices become available.



**12-PIN SOCKETS** for G-E Compactron devices are now available — two in a plastic bag, at nominal cost — from G-E Tube distributors. They fit a 1 1/8-inch chassis hole, with mounting holes spaced 1 1/8 inches. Ask for ETR-2976 at your G-E distributor.

## CONDENSED SPECIFICATIONS OF CURRENT G-E COMPACTRON™ DEVICES

TYPE	DESCRIPTION	CHARACTERISTICS SIMILAR TO	BASE	HEATER	DIMENSIONS IN INCHES DIA. "A" HEIGHT "B"	
1AD2	HV Diode	1J3 High-Voltage Rectifier	12DQ	1.25V 0.2A	1.19	3
2AH2*	HV Diode	3A3 High-Voltage Rectifier	12DG	2.5V 0.3A	1.19	3
6AG11	Duplex-Diode Twin Triode	6AL5 Diodes plus 12AT7 Triodes	12DA	6.3V 0.75A	1.19	1.5
6AS11	Dissimilar-Double-Triode Pentode	6AU8 Triode Section plus 6CX8 Triode-Pentode	12DP	6.3V 1.05A	1.19	2.25
6AV11	Triple Triode	Three 12AU7 Triode Sections	12BY	6.3V 0.6A	1.19	1.5
6AX3*	TV Damping Diode	6AX4-GTB TV Damping Diode	12BL	6.3V 1.2A	1.19	2.25
6B10*	Duplex-Diode Twin Triode	12AU7 Twin Triode plus 2 Diodes	12BF	6.3V 0.6A	1.19	1.5
6C10*	Triple Triode	Three 12AX7 Triode Sections	12BQ	6.3V 0.6A	1.19	1.5
6D10*	Triple Triode	Three 12AT7 Triode Sections	12BY	6.3V 0.45A	1.19	1.5
6FJ7	Dissimilar Double Triode	6DN7 Double Triode	12BM	6.3V 0.9A	1.19	2
6G11	Dissimilar Double Pentode	6DT6 Pentode Plus 6CU5 Audio Pentode	12BU	6.3V 1.2A	1.19	2
6GE5	Beam Power Pentode	6DQ6-B TV Horizontal Sweep Amplifier	12BJ	6.3V 1.2A	1.56	2.5
6GF5	Beam Power Pentode	6BQ6-GTB TV Horizontal Sweep Amplifier	12BJ	6.3V 1.2A	1.19	2.5
6J11	Twin Pentode	Two 6EW6 High-Gm Pentodes	12BW	6.3V 0.8A	1.19	1.5
6K11*	Three-Section Triode	12AT7 Twin Triode plus One 12AU7 Section	12BY	6.3V 0.6A	1.19	1.5
6M11	Twin-Triode Pentode	12AT7 Twin Triode plus 6EW6 Pentode	12CA	6.3V 0.775	1.19	1.5

\*Types available from G-E Tube distributors immediately; other types are in production and will be available shortly.

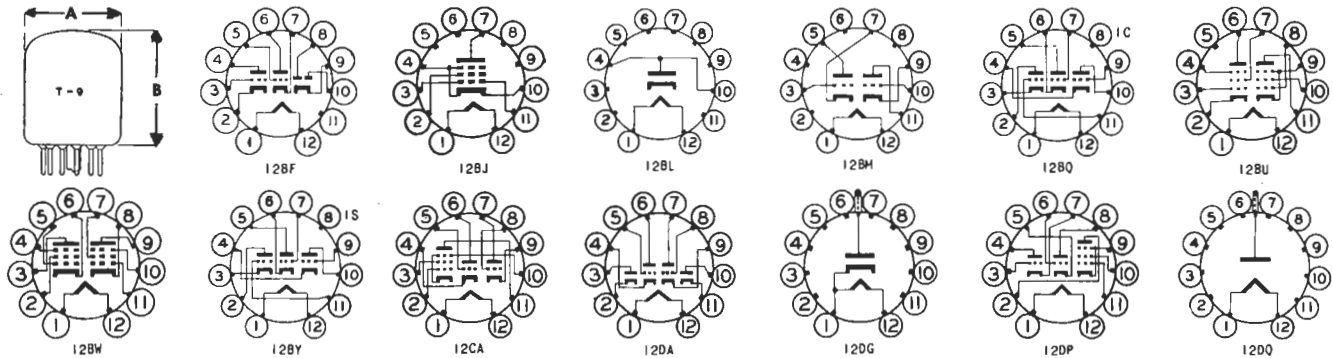

Available **FREE** from your G-E Tube Distributor

JANUARY-FEBRUARY  
1962  
VOL. 17, No. 1