

# The W2FMI Ground-Mounted Short Vertical

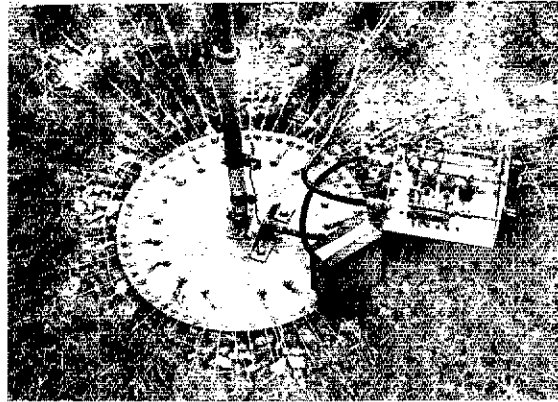

The matching network and base hardware showing 115 radials with the 6-foot vertical. The pi network is covered with a plastic bag.

BY JERRY SEVICK,\* W2FMI

A SHORT VERTICAL antenna, properly designed and installed, approaches the efficiency of a full-size resonant quarter-wave antenna. Even a six-foot vertical on 40 meters can produce an exceptional signal. Theory tells us that this should be possible, but the practical achievement of such a result requires an understanding of the problems of ground losses, loading, and impedance matching. This paper covers design principles which are applicable to all of our amateur bands.

## Background

Earlier work by the author<sup>1</sup> on the radiation efficiency of a ground-mounted vertical resulted from the desire to design a simple, inexpensive, low-profile DX beam for 20 meters. This first work reviewed the theoretical considerations involved and pointed out that a good ground system is essential to achieve efficient operation of a resonant quarter-wave antenna. The second work applied these results to a 20-meter beam.<sup>2</sup> In the process of trying to extend the results of these investigations to the 40-, 80- and 160-meter bands, and to possible multiband operation, the need arose to understand the operation of a shortened vertical and the effects of different loading schemes on the input impedance.

\* Director, Technical Relations; Bell Telephone Laboratories, Murray Hill, NJ 07974.

<sup>1</sup> Sevick, "The Ground-Image Vertical Antenna," *QST* July, 1971.

<sup>2</sup> Sevick, "The W2FMI 20-Meter Vertical Beam," *QST*, June, 1972.

The 10-foot, 40-meter vertical designed for an input impedance of 12.5 ohms in order to use a 4:1 step-up bifilar transformer. The top hat has a diameter of 4 feet and the coil, placed one foot below, has 14 turns. Shown at the base is the transformer and impedance bridge.

The first part of this paper deals with the theoretical considerations of a short vertical antenna and the experimental procedures involved in measuring the various parameters. This is followed by experimental results which show the trade-offs involved in shortening antennas by various loading schemes. Finally, specific designs are given for the 40- and 80-meter bands.

## Theoretical and Experimental Considerations

There are several old familiar axioms in amateur radio that are not completely understood by the amateur. I refer specifically to the two sayings: *make the antenna as long as possible and erect it as high as possible*, and, *a full-size beam is better than a smaller beam, and a tall vertical is always better than a short one*. The first axiom is particularly relevant to horizontal antennas where height is most important for reliable DX operation.<sup>3</sup> Increasing the length tends to increase the gain in certain directions. But with the vertical antenna, taking it off the ground and feeding it at a voltage point (like the *J* antenna) in order to eliminate radials can result in poorer performance because of

<sup>3</sup> See footnote 1.



March 1973

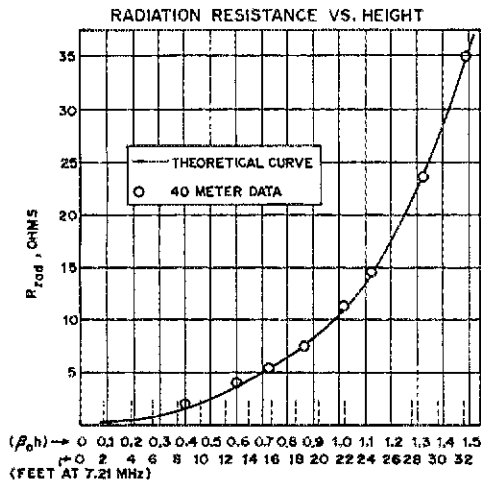

Fig. 1 -- Theoretical curve and experimental results for the radiation resistance as function of height.

increased earth loss.<sup>4,5</sup> More experimental work remains to be done on this phase of vertical antennas. The second axiom noted above is generally true, but misinterpreted by many. I refer to those important properties: power gain – important in transmitting and capture cross-section – important in receiving. (Power gain is the gain, in magnitude, compared to an isotropic radiator; cross-section is a fictitious area related to the ability of the antenna to intercept the radiated power and make it available to the receiver for detection.) As will be seen below, very little is compromised in these properties by shortening the antenna.

The short antenna has been defined as one that is small compared to a wavelength. In a more exact form, it is defined in such a manner as to simplify the mathematics in the theoretical calculations.

<sup>4</sup> Miller, Poggio, Burke, Seldon, "Analysis of Wire Antennas in the Presence of a Conducting Half-Space, Part II. The Vertical Antenna in Free Space," *Canadian Journal of Physics*, Vol. 50, 1972.

<sup>5</sup> Feldman, "The Optical Behavior of the Ground for Short Radio Waves," *Proc. of the Inst. of Radio Engineers*, Vol. 21, No. 6, June, 1933.

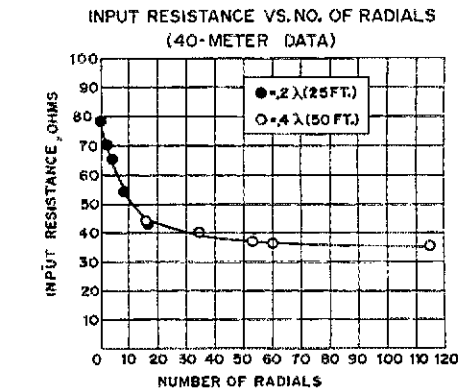
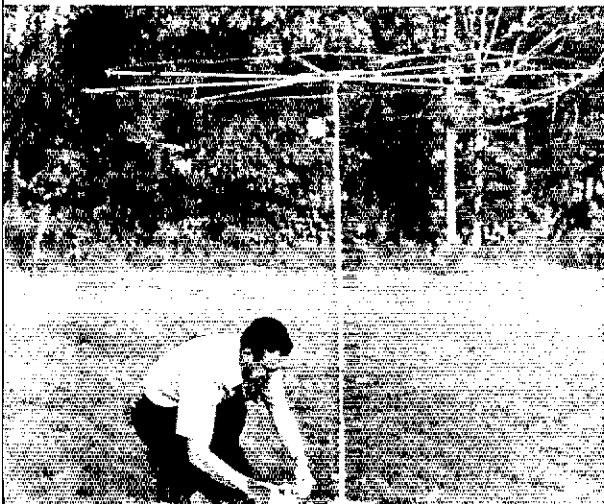

Fig. 2 -- Input resistance of a quarter-wave ground-mounted resonant vertical as a function of the number of radials.

King<sup>6</sup> has used the following inequality as the definition

$$\beta_0 h \leq 0.5$$

where

$$\beta_0 = \frac{2\pi}{\lambda}$$

h = half-length of a center-fed antenna or the height of a ground-mounted vertical.

λ = the wavelength

$\beta_0 h$  is actually a quantity which is used to express the height of an antenna in terms of an angle in radians. Thus, this quantity is independent of the frequency. Since 40 meters was used mostly for experimental results presented in this article, the inequality above assures accurate theoretical calculations for verticals of eleven feet or less.

The theoretical results show that the power gain for a very short antenna, even less than one foot high on 40 meters, is 1.5.<sup>7</sup> This increases slowly to 1.513 for an eleven-foot antenna. These gains are to be compared to about 1.62 for a resonant quarter-wave vertical. It can be seen that this difference amounts to less than 0.4dB or 0.07 S unit, based on 6 dB per S unit.

In a similar fashion, the capture cross-sections differ by relatively small amounts. For the very short antenna, a cross-section value is  $0.119 \lambda^2$ , while for the quarter-wave vertical it is  $0.13 \lambda^2$ . This is surprising to many since it is difficult to visualize a vertical of a foot or two in height on forty meters, having practically the same receiving ability as a 33-foot quarter-wave antenna!

But the important property of a short vertical that makes its capture cross-section nearly the

<sup>6</sup> King, *The Theory of Linear Antennas*, Harvard Univ. Press, Cambridge, MA 1956.

<sup>7</sup> See reference in footnote 6, p. 497.

The author with the 6 foot, 40-meter vertical.

**QST for**

equivalent of a full  $1/4\lambda$  antenna is its *very small value of input resistance*. Fig. 1 shows the theoretical curve, and the 40-meter experimental results, for the input resistance of a ground-mounted vertical as a function of height.<sup>8</sup> The experimental data were obtained by essentially canceling out the capacitive reactance of the vertical by an inductance at the base of the antenna and measuring the resistive value with an impedance bridge. Since an extensive, low-loss radial system was used, the resistance measured was actually that of the antenna itself, which is called the *radiation resistance*.

Fig. 2 shows the input resistance of a quarter-wave resonant vertical as a function of the number of radials. At the 115-radial point, the input resistance approaches the theoretical value of 35 ohms which strongly indicates low earth loss and hence reliable data in short antenna measurements. The picture also shows the base hardware for 60 radials. The wire is 15-gauge aluminum and was purchased at Sears. As mentioned in a previous article, there is nothing sacred about 15 gauge. No. 22 wire, or even No. 28, would be just as good.

It should also be noted that very little difference was noted whether  $0.2\lambda$  or  $0.4\lambda$  radials were used. At 16 radials, the results are practically identical. In fact, this curve is also similar to the one obtained on 20 meters which was reported earlier.<sup>9</sup> More work remains to be done on the trade-offs in performance versus length of radials for ground-mounted verticals.<sup>10</sup>

**Experimental Results**

In designing a shortened vertical beam for 40, 80 or 160 meters, a most important consideration is the value of the input impedance of the driven element. As seen by Fig. 1, a shortened vertical using base loading has an extremely low value,

<sup>8</sup> See reference in footnote 6, p. 190.

<sup>9</sup> See footnote 1.

<sup>10</sup> Weeks, *Antenna Engineering*, p. 48, McGraw-Hill Book Company, 1968.

TABLE I - Inductive Loading

1) Base Loading			
	No. of turns <sup>+</sup>	h	R <sub>rad.</sub>
a)	7	24 feet 3 inches	14.5 ohms
b)	10	18 feet 9 inches	7.5 ohms
c)	12	15 feet 7 inches	5.5 ohms
d)	14	13 feet	4 ohms
e)	18	8 feet 10 inches	2 ohms
2) Midpoint Loading			
	No. of turns <sup>+</sup>	h	R <sub>rad.</sub>
a)	6	28 feet 5 inches	28.5 ohms
b)	11	24 feet 3 inches	25.2 ohms
c)	15	19 feet 8 inches	16.5 ohms
d)	18	15 feet 8 inches	12.3 ohms
e)	24	14 feet 6 inches	10.5 ohms
3) Three-Quarter Point Loading			
	No. of turns <sup>+</sup>	h	R <sub>rad.</sub>
a)	10	29 feet 4 inches	32.5 ohms
b)	18	23 feet	26 ohms
c)	23	21 feet 2 inches	23.5 ohms
d)	24	19 feet 2 inches	22 ohms

<sup>+</sup> B & W 3029, 2-1/2 in. dia., 6TPI, No. 12 wire.

particularly at one-eighth wavelength and less. This input impedance is then usually lowered in the presence of other elements in a beam array. The resulting very low value of input impedance makes it difficult to design matching networks. Therefore, an experimental investigation was undertaken to see what increases in radiation resistance could be obtained by other methods of loading, i.e., top hat, three-quarter point, midpoint, and distributed (helical antenna). The results of these experiments are shown in Fig. 3. Table I shows the individual points for inductive loading and Table II for top hat and distributive loading. Several interesting points were brought out by these experimental results. Fig. 3 shows that top-hat loading yielded

TABLE II - Top Hat and Distributed Loading

1) Top Hat Loading (4-spoked wheel with 1/8-inch Al wire rim)				
	Diameter	h	R <sub>rad.</sub>	
a)	1 foot	30 feet 10 inches	34 ohms	
b)	2 feet	28 feet 7 inches	32.5 ohms	
c)	4 feet	24 feet	30 ohms	
d)	7 feet	19 feet 2 inches	23.5 ohms	
e)	4 feet <sup>+</sup>	23 feet 4 inches	29.4 ohms	
2) Distributed Loading (Helical Antenna)				
	No. of turns	h	R <sub>rad.</sub>	Top Hat at 1.5 feet Above Coil
a)	111	12 feet	8 ohms	1 foot dia.
b)	105	12 feet	10 ohms	2 feet dia.
c)	113	7 feet	6 ohms	2 feet dia.
d)	75	7 feet	7.5 ohms	4 feet dia.

<sup>+</sup>8-spoked wheel



Eight-and-one-half-foot helical antenna using a 2-foot top hat 1-1/2 feet above the 7-foot helix. The 75 turns have approximately a 3-inch pitch below the midpoint and 1.5-inch pitch above. Very little difference was noted in reversing the pitches. The input impedance was 7.5 ohms.

the largest value of radiation resistance for a particular height. Surprisingly, the helical antenna<sup>11</sup> yielded a value less than midpoint loading. The three-quarter point and midpoint loading curves were not extended to lower values of height because data were very difficult to obtain below the points shown on the respective curves. The combinations of inductances and lengths below the heights shown on these two curves were probably beyond resonant conditions at the frequency used in the measurements. The other curves were extended by dashed lines indicating no difficulties were encountered in the measurements and other lengths were very possible.

Another interesting aspect of the top-hat loading curve is that a four-spoked wheel approaches to a good degree a solid disk. Doubling to eight spokes only improves the loading by about 9 percent as noted in Table II. Thus, a few radials on the top of a vertical are very effective.

Four radials at the base, approximating a ground system, are practically useless as noted in

<sup>11</sup> The diameter of the helical antenna was 1-5/8 inches. Each helical antenna had a top hat 18 inches above the helix in order to terminate the upper turns with sufficient capacitive reactance.

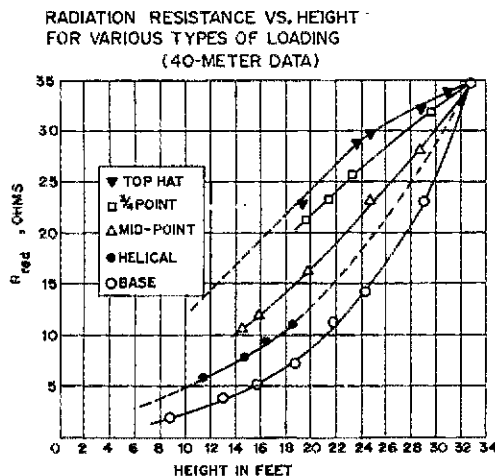

Fig. 3 — Experimental results of radiation resistance as a function of height of antenna for various types of loading (40-meter data).

Fig. 2. Also, it can be seen from Table II that the reduction in length because of top-hat loading is approximately equal to twice the diameter of the disk.

On 160 meters, top hats have been made with sloping wires or struts with success.<sup>12</sup> Because of the sloping nature of this top hat, some cancellation of the antenna current takes place, thus reducing the radiation resistance further.

Although the curves in Fig. 3 were obtained from experiments at 7.21 MHz, these data can be applied to the other bands by proper scaling. For example, by doubling all dimensions, including the number of turns of the loading coils, the radiation resistance values would apply at a frequency of 3.6 MHz. By increasing the dimensions by only 1.85 instead of 2, the results would then apply to a frequency of 3.9 MHz. In like manner, a proper scaling factor could be used to apply these results to a portion of any of the amateur bands.

#### 40- and 80-Meter Short-Vertical Designs

As was stated before, a most important consideration in designing short verticals is a knowledge of the input resistance and how it varies with different types of loading. The objective is to obtain a resistance value large compared to earth losses, so that efficient operation is obtained. In the author's specific case, using 115 radials, practically no earth loss was measured, and, hence, any radiation resistance above a few ohms assured good operation and an opportunity to verify the theoretical predictions for very short vertical antennas.

Since a broad-band, bifilar, four-to-one step-up transformer was available from previous work,<sup>13</sup> the first design was for the shortest vertical having an input resistance of 12.5 ohms. From the curves of Fig. 3, it appeared that a 16- or 17-foot antenna with a coil of some 13 turns (extrapolated from Table I) at 8 or 9 feet from the base would provide the proper impedance at 40 meters. Further, it was decided that some 7 or 8 feet of length above the coil could be replaced by an eight-spoked top hat having a diameter of four feet. The actual design that resulted, after proper tuning, is shown in the

<sup>12</sup> See reference in footnote 10, p. 44.

<sup>13</sup> See footnote 2.

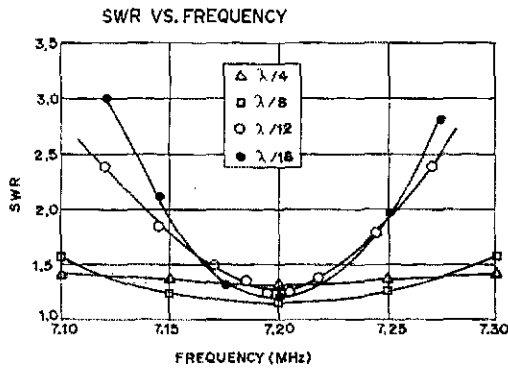

Fig. 4 — Standing wave ratio of various short verticals compared to a resonant quarter-wave antenna. The sixteenth wavelength antenna is the 8-1/2-foot helical design, the twelfth wavelength is the 10-foot antenna, and the eight wavelength is the 15-foot, 10-inch antenna. (All three are described in the text.)

picture. The antenna had a total height of only 10 feet and a 14-turn coil placed one foot below the top hat. This height was about one foot higher than first expected, but upon careful examination it was noted that the top hat also reduced the radiation resistance, while replacing a section of the vertical portion. Therefore, the height had to be increased somewhat when considering top-loading effects. Also shown in a picture are the construction details for the top hat.

Two other shortened verticals for 40 meters were investigated. One was an 8-1/2-foot helical using a four-foot top hat and 75 turns on a 1-5/8-inch, 7-foot long, wooden dowel. The input impedance was 7.5 ohms and it was matched with a standard pi network. Pictures are shown with the network. Several tests were made by doubling the winding pitch below and above the midpoint, keeping the number of turns constant, with very little difference in results.

The second antenna, also for 40 meters, using a 7-foot top-hat, resulted in a matched vertical only

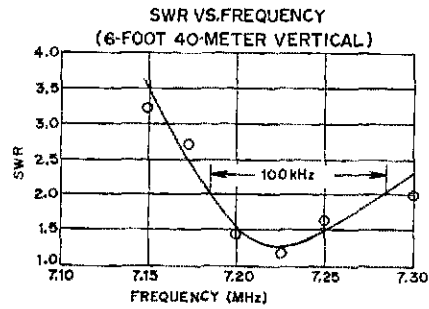

Fig. 5 — Standing wave ratio of the six-foot vertical using a 7-foot top hat and 14 turns of loading 6 inches below the top hat.

6 feet high. It had a 14-turn coil, six inches below the top hat and an input impedance of only 3.5 ohms. Matching was accomplished with the 4-to-1 transformer and the pi network. A picture of the antenna and matching network is shown.

A larger 40-meter vertical antenna was also investigated. It had a four-foot top hat and 7 turns of base loading which resulted in a height of 15 feet 10 inches (approximately 1/8 wavelength) and an input impedance of 12.5 ohms. The purpose of this design was to compare its low-angle radiation and bandwidth<sup>14</sup> with the other antennas. Table III shows the parameters of these various short vertical designs. Fig. 4 shows the SWR curves of three of the short antennas compared to a quarter-wave resonant vertical and Fig. 5 shows the SWR of the six-foot antenna.

As can be seen by the SWR curves, shortening an antenna generally decreases its bandwidth. Also by comparing the 8-1/2- and 6-foot antennas, top-hat loading appears to affect the SWR the least. It should also be noted that an eighth-wavelength antenna appears to have a reasonable bandwidth and would probably result in a practical beam design.<sup>15</sup>

<sup>14</sup> Bandwidth is defined as the range in frequency where SWR is less than 2 to 1.

<sup>15</sup> See footnote 2.

Table III  
Parameters of the 40-Meter Short Vertical Designs

Total Height	R <sub>rad.</sub> (ohms)	No. turns <sup>16</sup>	Dia. Top (feet)	Bandwidth
6 feet	3.5	14	7	100 kHz
8-1/2 feet	7.5	at 6 inches below top hat		
8-1/2 feet	7.5	75 on 7 foot dowel 1-5/8 inches in dia.	4	100 kHz
10 feet	12.5	14 one foot below top hat	4	125 kHz
15 feet 10 inches	12.5	7 at base	4	540 kHz

<sup>16</sup> Except for helical antenna, coil wire is same as shown in Table I.

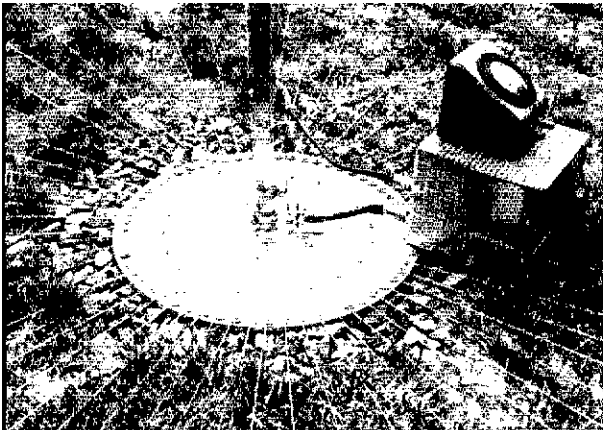

Base of the vertical antenna with 60 radials. The aluminum disk is 15 inches in diameter and 1/4 inch thick. Sixty tapped holes for 1/4-20 aluminum hex-head bolts form the outer ring and 20 form the inner ring. The insulator is polystyrene material with a one inch diameter. Also shown is the impedance bridge for measuring input resistance.

Originally, circular wires were used to connect all radials together. These were positioned every two feet, starting from the antenna base. Then, one at a time, they were removed, meanwhile keeping a check on the antenna radiation resistance. There was no apparent change in the radiation resistance so it was concluded that the interconnecting rings of wire were not needed in the ground system.

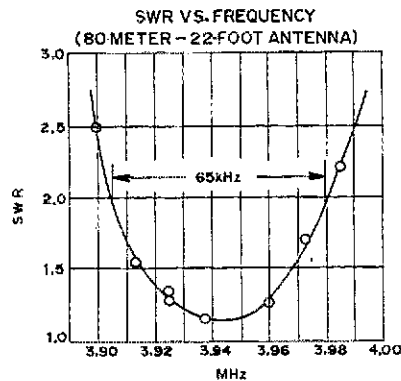

Fig. 6 -- The standing wave ratio for the 22-foot, 80-meter vertical.

And finally, the four short-vertical designs described above were compared with a resonant quarter-wavelength antenna for low-angle radiation and on the air with other amateur signals. The low-angle radiation measurements were made at three wavelengths in distance and at heights of 1, 3, 6 and 8 feet. This relates to vertical angles of 0.15, 0.45, 0.90 and 1.2 degrees respectively. All measurements were made under matched conditions and with a constant 100 watts fed into the antennas under test. In no case were there any appreciable differences noted in the field strength measurements. In fact, the six-foot antenna seemed

to give slightly higher readings! These measurements certainly tend to verify the theory on the power gain predicted for short verticals. On-the-air checks were again very gratifying and exciting. Over two hundred contacts with the six-foot antenna strongly indicated the efficiency and capability of a short vertical. Invariably at distances greater than 500 or 600 miles, the short verticals yielded excellent signals.

As was stated previously, all of the results obtained by measurements on 40 meters can be scaled, by the appropriate ratios of frequencies, to other bands. This was tried out on 80 meters. Since a seven-foot top hat was available (instead of an eight-foot one), the height turned out to be 22 feet instead of 20. The loading coil had 24 turns and was placed two feet below the top hat. On-the-air results duplicated those on 40 meters. The bandwidth was 65 kHz (half of the 40-meter value) as shown in Fig. 6.

### Conclusions

Several interesting results came out of this investigation which, even to one schooled in antenna theory, are difficult to believe. I refer specifically to the ability of very short verticals to radiate and receive as well as a full-size quarter-wave antenna. The differences are practically negligible. But, as was seen, the trade-offs are in lowered input impedances and bandwidths. However, with a good image plane and a proper design, these trade-offs can be entirely acceptable.

As a result of this investigation, other problems were noted which indicate the need for further experimentation. I refer specifically to the trade-offs encountered when shortening the radials (to 0.1 wavelength, for example), the efficiency of ground-mounted versus elevated verticals as a

*(Continued on page 41)*

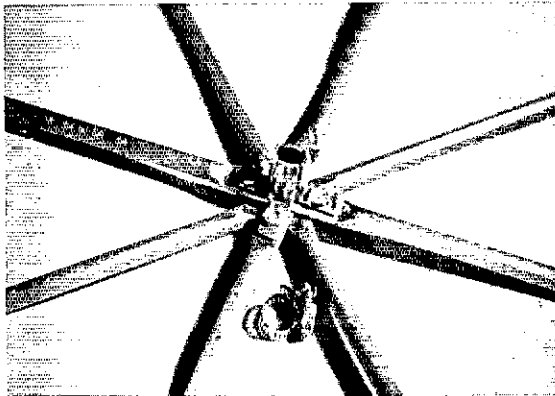

Construction details for the top hats. For diameters of 4 and 7 feet, half-inch aluminum tubing was used. The hose clamp is of stainless steel and available at Sears. The rest of the hardware is all aluminum.

**Construction Details**

The major problem that presented itself was how to mount the unit without causing damage to the cabinet of the 32S-3. A 2-inch aluminum bracket was made and hooked at one end to the front lip of the transmitter, and through the mobile mount in the rear. The bracket is made taut by bolts which can be tightened. This system means that no holes need be drilled in the cabinet. To this bracket a 2 x 2 x 6-inch aluminum box (which houses the solenoid and its mechanism) was riveted. The solenoid was then mounted to one end of the aluminum box by means of two aluminum straps.

The actuating mechanism consists of a 1/4 x 3/16 x 1/4-inch aluminum bar which reaches from the outboard solenoid box to the spotting button. Two 1/8-inch rods are tapped into the bar and backed up with stop nuts. These rods run from the actuating bar into the solenoid box. The reason that two 1/8-inch rods were used was to assure the positioning of the aluminum bar over the spotting button. A spring is utilized to return the bar to the neutral position after the solenoid has been released. Bearings for the two linkage rods are made from two 3/8-inch bolts. A hole is bored through the center of each bolt, slightly larger than 1/8 inch, to provide a sliding fit for each rod. In order to limit the outward travel of the arm when the solenoid is released, a sleeve is fabricated and slipped over one of the rods. The inner diameter of the sleeve should be slightly larger than 1/8 inch, to provide either a sliding or snug fit with the rod. Inward travel of the rod is limited by the position of the bar itself. Adjustment of this inward travel is accomplished by adjusting the depth of the rods into the bar. Once the adjustment is made, the stop nuts are tightened.

The travel of the spotting bar should be setup as shown in Fig. 1. This is important since if the arm is allowed too much travel, the force of impact is increased and the chances of damage to the 32S-3 spotting switch are greater.

**Using the Switch**

A momentary switch located at the key for easy access, is used to actuate the solenoid (Fig. 2). Now spotting is much simpler, since one hand can

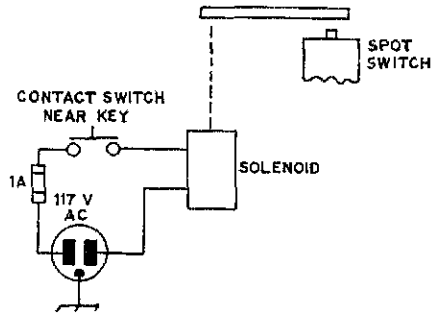
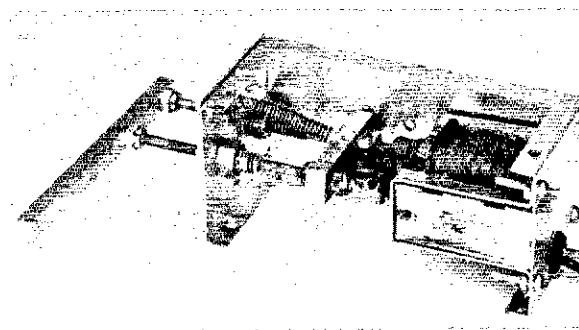

Fig. 2 — Schematic diagram of solenoid and momentary switch.



Close-up view showing solenoid, actuating mechanism, and return spring. The limit sleeve is on rod behind return spring.

be at the key while the other is turning the VFO knob. As soon as you have spotted, you can start sending, not having to take your hand off the transmitter and reach back over to the key. During about two months of operation, no problems have been encountered with the spotting unit.

The solenoid which was used in the system was found to have much more pull than was necessary. If a smaller one could be obtained, it would be advisable to use it. The aluminum box was purchased at Radio Shack. The rest of the parts were of junk-box origin and a homemade spring was used to return the solenoid to the neutral position. QST

**W2FMI Vertical**

*(Continued from page 18)*

function of height above ground, the characteristics of a multiband vertical over a low-loss image plane, and a shortened vertical beam using elements of the order of an eighth wavelength. These, I hope, will be reported in subsequent articles.

Another point should be mentioned in relation to the results reported here. Even though they

were obtained on short ground-mounted verticals, they are valid for center-fed verticals or horizontal antennas as well. The only differences are that the impedance values should be doubled and the effect of the image antenna accounted for.

I would like to acknowledge the support of many amateurs for their fine words of encouragement and excellent reporting during on-the-air contacts. In this study, some 350 amateurs reported on comparisons between signals from these short verticals and those of other stations. QST