

# ham tips

December 1969 | Volume 29 Number 3

## A Magnetic-Tape Keying System for Code Recording and Transmission

By George D. Hanchett, W2YM

RCA Electronic Components\*



The author is shown recording code on magnetic tape. The tape will be used either for code practice or to key the transmitter.

Equipment for mechanically keying a transmitter by means of a tape recorder can be a desirable addition to the ham shack. Not only can it be used for "skeds" and for automatic-calling in contests, but to provide code instruction as well. Code can be recorded at one speed and played back at another; thus it is possible to double or even halve the original rate.

Actually more than a simple keyer, the W2YM magnetic tape-to-code converter can also be used to record voice transmissions. As an additional feature, its side-tone oscillator can be combined with the mixer to form an excellent code-monitoring device.

The basic elements of the system consist of a tape recorder, tape-to-relay converter, keying relay, code oscillator, and key. No alterations are required of the tape recorder and use of the converter is extremely simple. The code oscillator is "built in" so that pitch will not vary with code speed. The parts cost of the equipment — excluding the tape recorder — totals about \$30.



Figure 1: The W2YM magnetic-tape keyer control, or "Keyer." All components are contained within a 7-by-5-by-3-inch minibox with the exception of the power transformer.

The magnetic-tape keyer control, or "Keyer," illustrated in Figure 1 is relatively easy to build because there are no sensitive circuits and most of the components are contained on a single 3-by-6-inch circuit board.

For the benefit of the builder, this circuit board is presented in considerable detail. In Figure 2, it is shown as a full-size component diagram and drilling template and, in Figure 3, as a schematic diagram with accompanying parts list. The photographs in Figures 4 and 5 respectively show the board as a completed unit and as part of the Keyer following installation. The completed board and the additional components of the Keyer are mounted in a 7-by-5-by-3-inch aluminum box with spacers separating the circuit board from the aluminum enclosure. Figure 6 shows a schematic diagram of the complete Keyer.

The terminals shown in the photographs were made by bending No. 18 solid bare wire around a 3/16-inch rod and inserting the ends of each "U" through No. 58 drill holes in the board. After insertion, the ends

of the wire terminals should protrude sufficiently from the underside of the board to permit point-to-point soldering of the connections with No. 22 plastic-coated wire. A printed circuit board can be used, of course, but only after some rearrangement of components to minimize the number of cross-overs. In any case, No. 60 holes should be drilled to accommodate component leads.

### Keyer Connections

The Keyer is readied for operation by making the connections described below and illustrated in Figure 7.

First, connect the "Rcvr Output" jack, J<sub>3</sub>, on the Keyer to the headphone jack on the communications receiver. Then connect shielded wire from the "Tape Input" jack, J<sub>1</sub>, on the Keyer to the "Line or Aux" input on the tape recorder. If the recorder has a "Line or Aux" output jack, also connect shielded wire from that jack to the "Tape Output" jack, J<sub>2</sub>, on the Keyer. If the tape recorder does not have a "Line or Aux" output, some modification of recorder wiring will be required prior to making this third connection (see Figure 8).

Next, connect the transmitter keying-relay contacts to the "Relay" terminals on the Keyer and plug in a hand or auto key at the "Key" jack, J<sub>4</sub>. The magnetic-tape keyer control is now ready for use.

Note that both hand and auto keys can be connected simultaneously, if desired, by using the "Key" plug on the front of the Keyer for one key and the "Key" terminals on the side of the Keyer for the second key. Volume-controlled audio output is available through the "Phones" plug, J<sub>5</sub>, on the Keyer, or through the receiver speaker (if the Keyer "Audio Output" terminals are reconnected to the receiver). The loudness of the signal in the phones is controlled by means of the "Phone Gain" control, R<sub>3</sub>, on

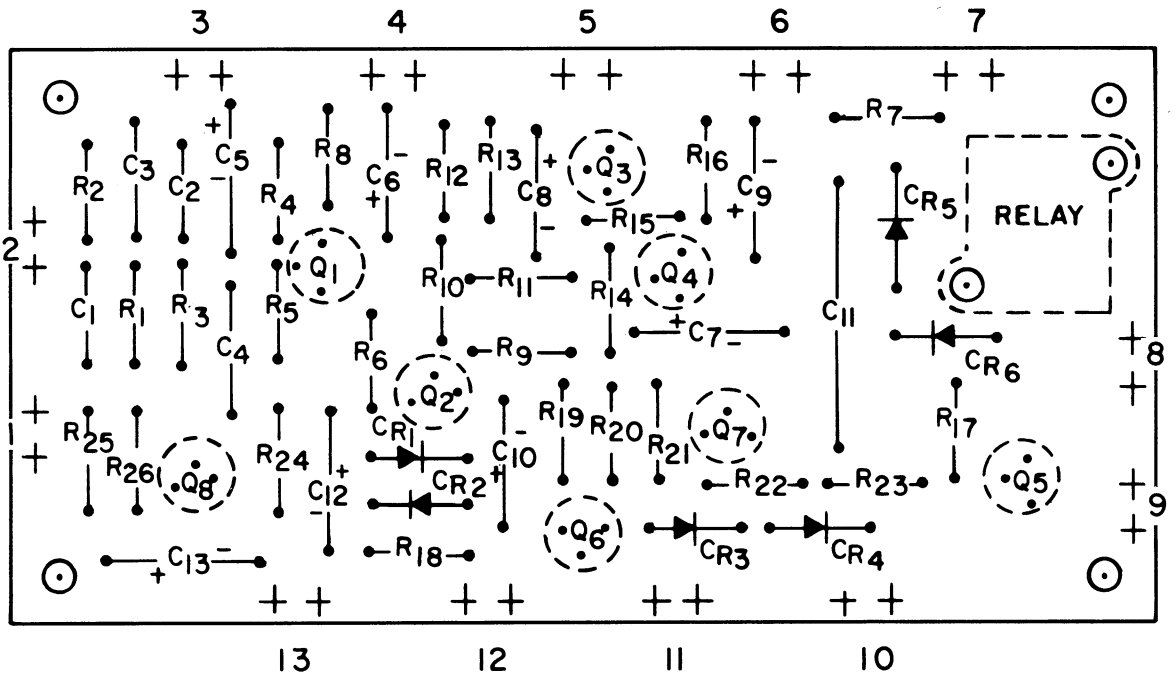

- KEY TO DRILLING SYMBOLS**
- No. 60 DRILL (0.040 INCH)
  - + No. 58 DRILL (0.042 INCH)
  - ⊙ No. 32 DRILL (0.116 INCH)

Figure 2: Circuit-board component-layout diagram and drilling template.

the Keyer. The loudness of the signal in the receiver speaker is controlled by the volume control on the receiver. The "Receiver" control, R<sub>1</sub>, on the Keyer is the input volume control and varies the signal level in both phones and speakers simultaneously.

**Keyer Operation**

Figure 7 shows the interconnections of the entire magnetic-tape keying system.

To operate the Keyer, set the "Selector" switch to position No. 1 and tune in a strong, readable, CW signal. The "Receiver" control should be approximately in mid-position after this adjustment. In switch-position No. 1, the Keyer amplifier is connected directly to the receiver through mixer input No. 1, and to the side-tone oscillator through mixer input No. 2. Adjust the gain control on the tape recorder to the proper recording level. A VU meter is a valuable tool in determining this level and in producing good tapes. If

the tape recorder being used does not have a VU meter, you can insert one into the circuit by use of the "Meter" plug on the side of the Keyer.

Next, depress the hand key and adjust the "Side Tone" control, R<sub>2</sub>, so that the signal from the side-tone oscillator is at the same level as the incoming CW signal. The Keyer is now set to act as a monitor of incoming and outgoing signals and to permit manual keying of the transmitter and recording of both incoming and outgoing signals.

As a succeeding step, record some text on the tape with the "Selector" switch in position No. 1. Then rewind the tape, set the "Selector" switch in position No. 2 — the tape playback position — and confirm proper operation of the Keyer and recorder by listening to the playback. When the "Selector" switch is in position No. 2, the tape recorder output is connected to mixer

Figure 3: Schematic diagram and parts list of Keyer circuit board.

$C_1, C_2$  — 0.012 microfarad, 200 volts, paper

$C_3$  — 0.027 microfarad, 200 volts, paper

$C_4$  — 0.01 microfarad, 200 volts, paper

$C_5$  — 20 microfarads, 15 volts, electrolytic

$C_6, C_8, C_{10}$  — 5 microfarads, 6 volts, electrolytic

$C_7, C_9, C_{12}$  — 5 microfarads, 12 volts, electrolytic

$C_{11}$  — 0.22 microfarad, 200 volts, paper

$C_{13}$  — 5 microfarads, 25 volts, electrolytic for solid-state receivers; 0.5 microfarad, 400 volts, paper for tube-type receivers

$CR_1, CR_2, CR_3, CR_4, CR_5, CR_6$  — silicon rectifier, type 1N3193

$Q_1, Q_2, Q_3, Q_4, Q_6, Q_7, Q_8$  — transistor, type 2N3242A

$Q_5$  — transistor, type 2N2614

$R_1$  — 2,700 ohms, ½ watt

$R_2, R_3$  — 27,000 ohms, ½ watt

$R_4, R_{25}, R_{26}$  — 100,000 ohms, ½ watt

$R_5$  — 22,000 ohms, ½ watt

$R_6$  — 6,800 ohms, ½ watt

$R_7, R_{17}$  — 470 ohms, ½ watt

$R_8$  — 2,200 ohms, ½ watt

$R_9, R_{10}, R_{18}, R_{24}$  — 1,000 ohms, ½ watt

$R_{11}, R_{20}$  — 1,200 ohms, ½ watt

$R_{12}, R_{13}, R_{19}, R_{21}$  — 10,000 ohms, ½ watt

$R_{14}$  — 820 ohms, ½ watt

$R_{15}$  — 120,000 ohms, ½ watt

$R_{16}$  — 220 ohms, ½ watt

$R_{22}$  — 680 ohms, ½ watt

$R_{23}$  — 1,500 ohms, ½ watt

Miscellaneous — Relay, Potter and Brumfield type RS5D (12-volt coil) or equiv.

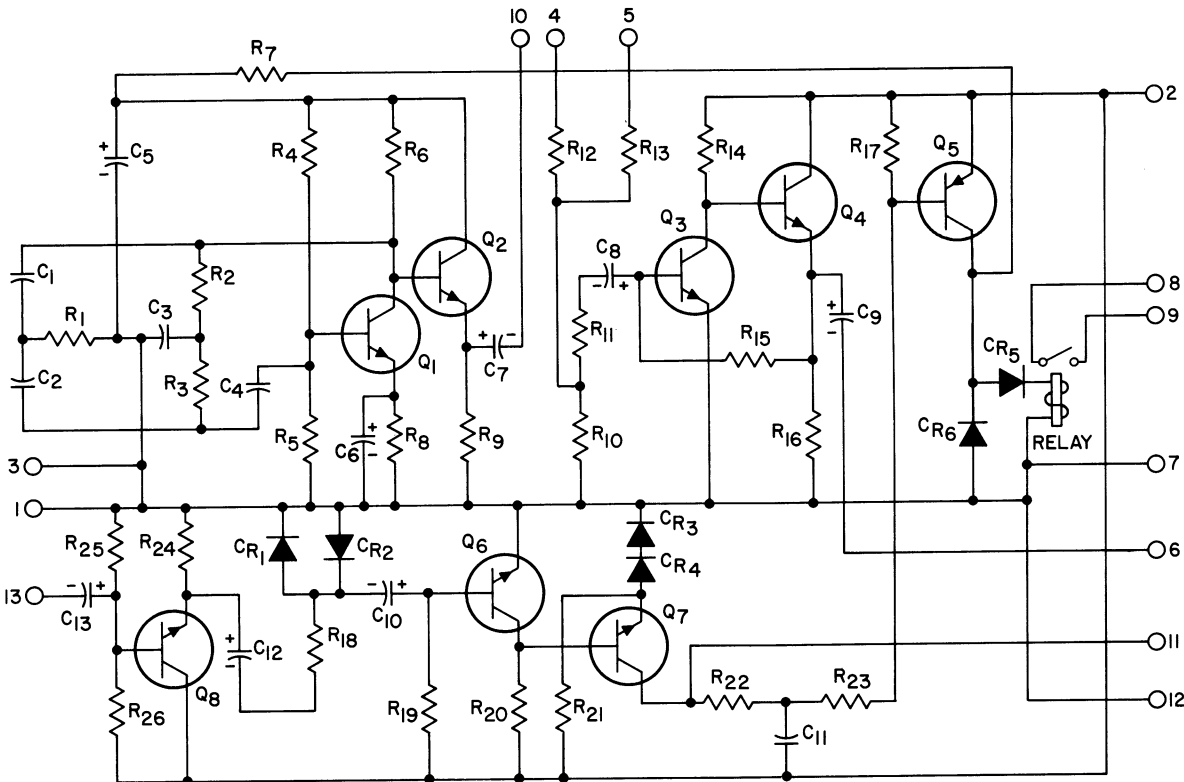

input No. 1 instead of to the receiver. Switch position No. 2 is used whenever taped material is to be checked.

In position No. 3, the selector switch connects the receiver to mixer input No. 1 and the amplifier output to the input of the audio keyer section of the Keyer. The output of

the side-tone oscillator is then impressed upon the tape recorder so that the tone recorded on the tape is that of the side-tone oscillator and not that of the actual incoming signal. The transmitter may be manually keyed and monitored when the "Selector" switch is in this position.

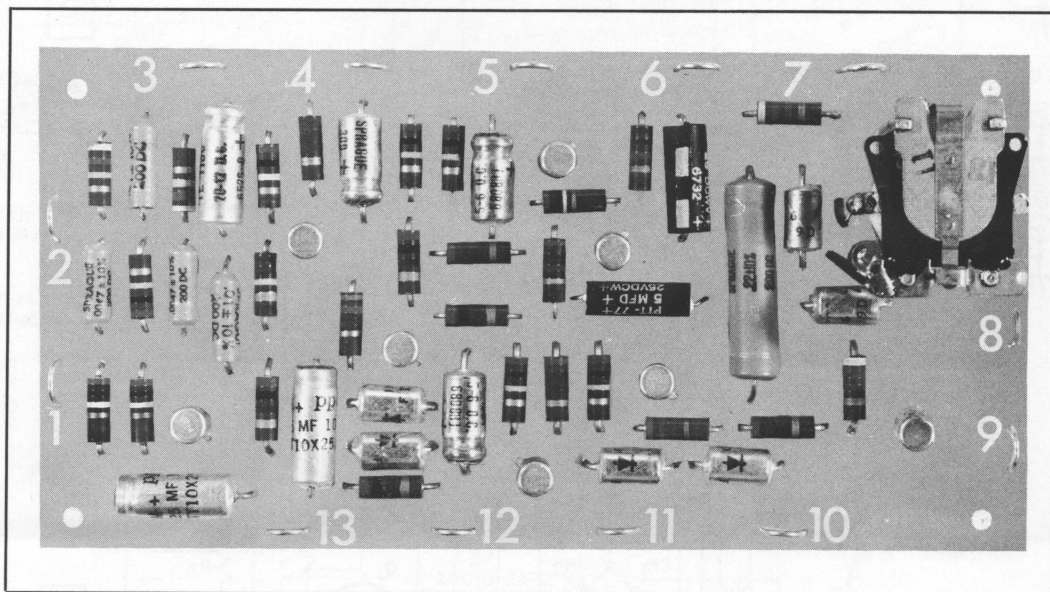

Figure 4: Completed circuit board.

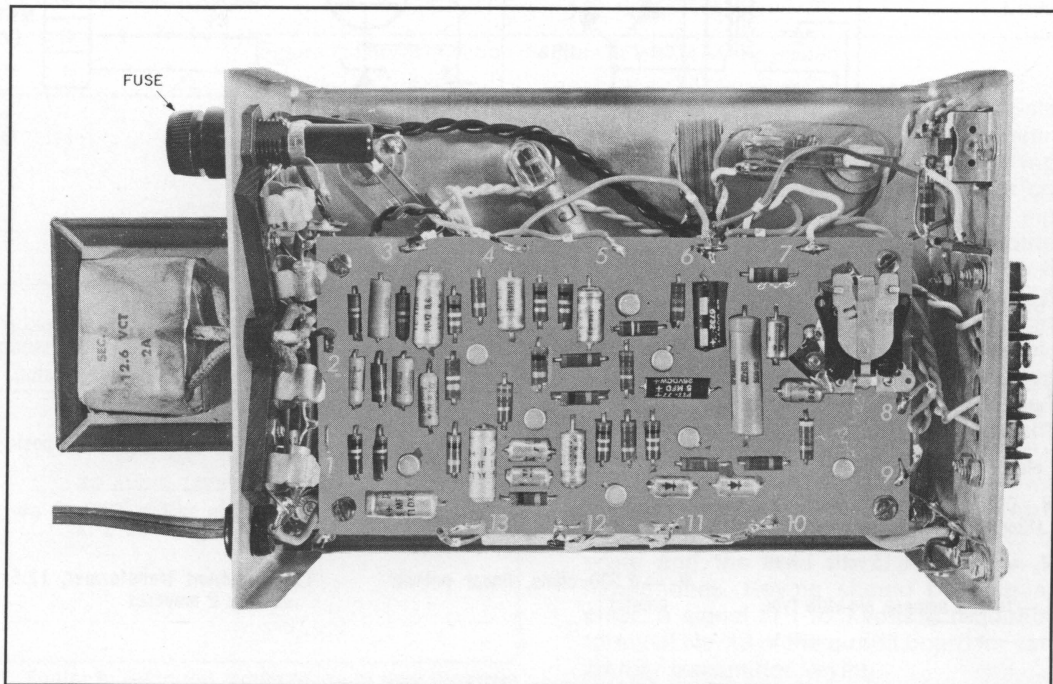

Figure 5: Completed Keyer with circuit board installed.



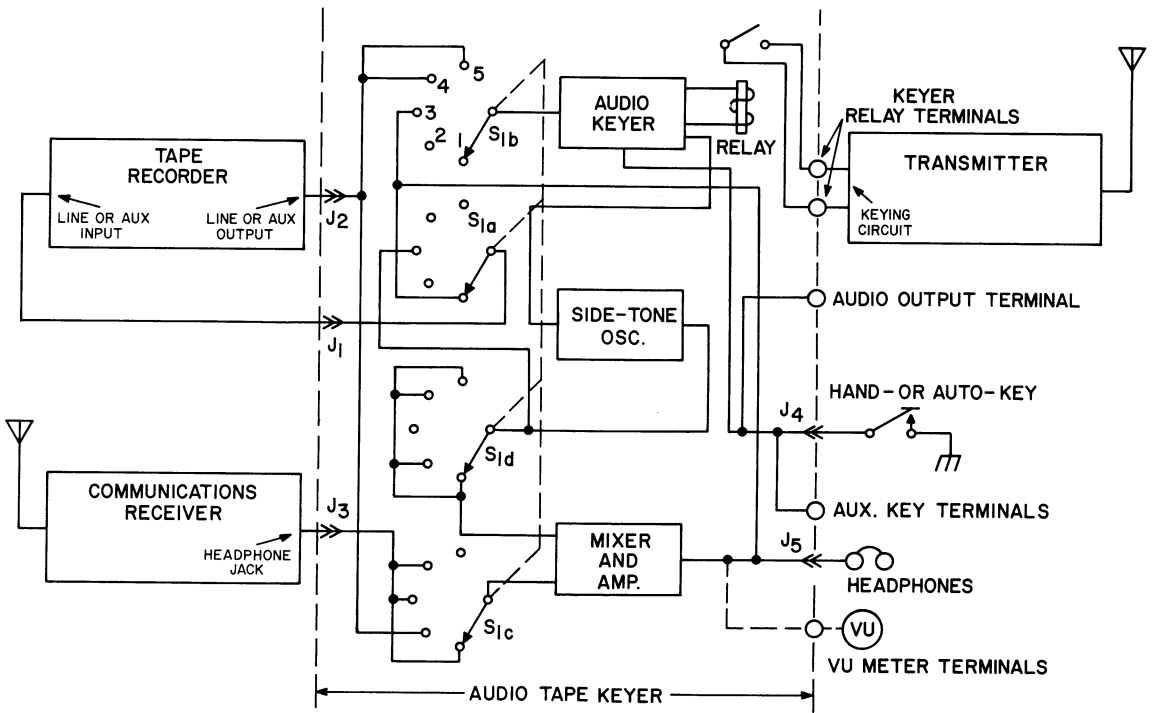

Figure 7: Interconnection diagram of W2YM keying system.

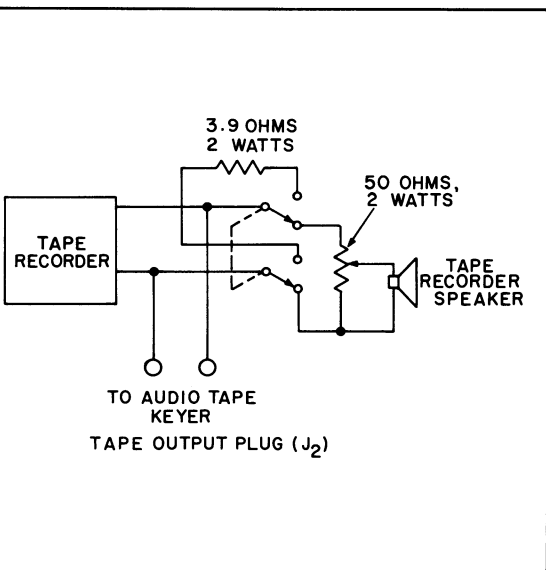

Figure 8: Required modification of tape recorder that has no "Line or Aux" output.

Again rewind the tape and set the "Selector" switch to position No. 4. In this setting, the receiver is connected to mixer input No. 1, and the side-tone oscillator is connected to the amplifier through mixer input No. 2. In addition, the "Line or Aux" output of the recorder is now connected to the input of the audio-keyer section of the Keyer. Position No. 4 of the "Selector" switch is the setting to be used to key a transmitter from a previously recorded tape. In this position, both incoming and outgoing signals may be heard and the transmitter may also be keyed manually.

To key the transmitter by tape, rewind the tape and adjust the output level of the tape recorder until the relay starts to operate and the side tone is heard in the headphones. Keying should be loud and clear. A signal of 1 to 3 volts is required at terminal No. 13 of the circuit board for satisfactory transmitter keying.

"Selector" switch position No. 5 is the

# RCA

HAM TIPS is published by the Electronic Components operation of RCA, Harrison, New Jersey. It is available from participating RCA Industrial Distributors or by writing to: RCA — HAM TIPS, 18-3, Harrison, New Jersey 07029.

DISTRIBUTED BY  
GEORGE D. BARBEY CO., INC.  
READING  
LANCASTER

LEBANON  
POTTSTOWN



Information furnished by RCA is believed to be accurate and reliable. However, no responsibility is assumed by RCA for its use; nor for any infringements of patents or other rights

of third parties which may result from its use. No license is granted by implication or otherwise under any patent or patent rights of RCA.

same as position No. 4 except that incoming signals cannot be heard.

When the system is used for code instruction, the Keyer's "Selector" switch should be in position No. 4. A recording made at a tape speed of  $7\frac{1}{2}$  inches-per-minute and a code speed of 20 words-per-minute can be used to teach code at 10 words-per-minute by halving the playback tape speed to  $3\frac{3}{4}$  inches-per-minute. For inexpensive recorders — in which tape speed is changed by manually changing the capstan — new capstans can be made that will permit transmission of code at almost any speed. The output of the amplifier

in the Keyer is sufficient to drive up to 10 pairs of high-impedance headphones or to feed the "Line or Aux" input of any tape recorder.

Table I summarizes the functions of the Keyer in the various switch positions.

Remember, the W2YM magnetic-tape keying system can be used to equal advantage for voice recording and playback as well as for code keying. In the relatively short period since its installation, the author has used this system almost daily, and has found it extremely helpful in DX operation — especially for the storage and replaying of weak-signal QSO's.

Table I — Keyer Functions

Selector Switch	Receive	Tape Key	Record	Playback	Monitor
Position #1	Yes	No	Yes	No	Incoming receiver signal and manually keyed side tone.
Position #2	No	No	No	Yes	Tape output and manually keyed side tone.
Position #3	Yes	No	Yes	No	Incoming receiver signal.
Position #4	Yes	Yes	No	No	Incoming receiver signal and manually and tape-keyed side tone.
Position #5	No	Yes	No	No	Same as Position #4.